

**2022**

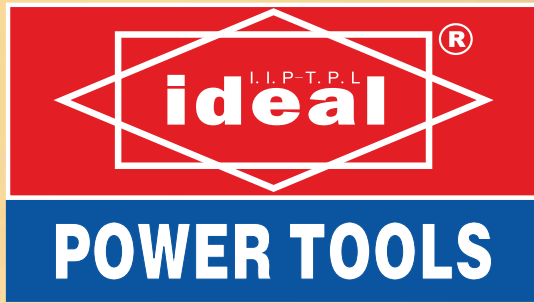



# POWER TOOLS

# CONTENTS

Electric Drill	01	Spray Gun	35
Angle Drill	02	Foam Spray Gun	35
Impact Drill	02	Cement Spray Gun	35
Rotary Hammer	03	Handy Paint Roller	35
Angle Grinder	05	Electric Spray Gun	36
Die Grinder	07	Airless Spray Unit	36
Straight Grinder	07	Manual Sprayer	36
Power Carver	07	Battery Sprayer	36
Marble Cutter	08	Grease Dispenser	36
Tile Cutter	09	Welding Machine	37
Wall Chaser	10	Welding Accessories	39
Groove Cutter	10	Chain Block	40
Slab Cutter	10	Electric Rope Hoist	40
Drill Stand	10	Diamond Blade	41
Grinder Stand	10	Glass Wheel	41
Bench Drill	10	TCT Blade	42
Cut-off Saw	11	Cut-off Wheel	42
Mitre Saw	12	Cutting Wheel	42
Demolition Hammer	13	D.C. Wheel	43
Core Drill	15	G.C. Wheel	43
Concrete Mixer	15	W.A. Wheel	43
Concrete Vibrator & Shaft	16	Flap Disc	43
Circular Saw	17	Fiber Disc	43
Wood Router	18	Polishing Wheel	43
Jig Saw	18	Water Paper	43
Electric Planer	19	HF Cut-off Wheel	43
Wood Trimmer	20	HF D.C. Wheel	43
Reciprocating Saw	20	HF G.C. Wheel	43
Electric Tacker	20	Armatures	44
Air Nailer	20	Switches	45
Chain Saw	21	Spare Parts	47
Chain Saw Chain	21	Bearing Pullers	48
Guide Bar	21	Beaker Grease	48
Brush Cutter	22	Router Bits	49
Auger Drill Machine	22	Router Bits Set	52
Lawn Mower	22	Wood Auger Bits	52
Hedge Trimmer	22	Auger Drill Bits	52
Power Tiller	22	Groove Cutter	53
Gasoline Generator	23	Planer Blade/knife	53
Gasoline Water Pump	24	Extension Pipe	53
Gasoline Engine	24	Webbing Sling	53
Sander & Polisher	24	Pallet Truck	53
Air Blower	26	Caulking Gun	54
Heat Gun	26	Torpedo Level	55
Chain Sharpener	26	Spirit Level	55
Vacuum Cleaner	27	Combination Square	55
Electric Mixer	27	Hand Files	55
Cordless Drill	28	Diamond File Sets	55
Magnetic Drill	28	Sharpening Tools	55
Bench Grinder	29	Metal Tool Box	55
Shear Machine	29	Hand Riveter	56
Electric Nibbler	29	Double Puller Riveter	56
Pressure Washer	30	Riveting Gun	56
Impact Wrench	31	Electric Riveter	56
Drill & Screw Driver	31	PVC Pipe Cutter	56
Pneumatic Tools	32	Grease Gun	56
Air Compressor	33		
Drywall Sander	35		
Pen Gun	35		



►► **ELECTRIC DRILL**

**ID ED02-6RF** 

**ELECTRIC DRILL**



Part No.: 26351

Rated Power Input	230w
No Load Speed	0-3800r/min
Max. Drilling Diameter	
Steel	6.5mm
Wood	9mm

**ID ED6RF** 

**ELECTRIC DRILL**



Part No.: 21696

Rated Power Input	230w
No Load Speed	0-4500r/min
Max. Drilling Diameter	
Steel	6.5mm
Wood	9mm

**ID ED10AR** 

**ELECTRIC DRILL**



Part No.: 26554

Rated Power Input	300w
No Load Speed	0-3000r/min
Max. Drilling Diameter	
Steel	10mm
Wood	18mm

**ID ED10AR(K.L.)** 

**ELECTRIC DRILL**



Part No.: 26537

Rated Power Input	300w
No Load Speed	0-3000r/min
Max. Drilling Diameter	
Steel	10mm
Wood	18mm

**ID ED10HQ** 

**ELECTRIC DRILL**



Part No.: 21690

Rated Power Input	400w
No Load Speed	0-3000r/min
Max. Drilling Diameter	
Steel	10mm
Wood	18mm

**ID SP10RE** 

**ELECTRIC DRILL**

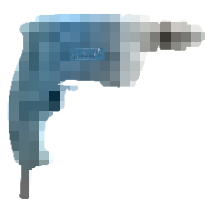

Part No.: 26723

Rated Power Input	450w
No Load Speed	0-4500r/min
Max. Drilling Diameter	
Steel	10mm
Wood	18mm

**ID 2313VR** 

**ELECTRIC DRILL**



Part No.: 27187

Rated Power Input	500w
No Load Speed	0-2800r/min
Max. Drilling Diameter	
Steel	13mm
Wood	18mm

**ID 504RE** 

**ELECTRIC DRILL**



Part No.: 26774

Rated Power Input	600w
No Load Speed	0-2800r/min
Max. Drilling Diameter	
Steel	6.5mm
Wood	9mm

**ID DU10** 

**ELECTRIC DRILL**



Part No.: 20233

Rated Power Input	600w
No Load Speed	0-1800r/min
Max. Drilling Diameter	
Steel	13mm
Wood	20mm

**ID DU13VRF** 

**ELECTRIC DRILL**



Part No.: 21686

Rated Power Input	500w
No Load Speed	0-1200r/min
Max. Drilling Diameter	
Steel	13mm
Wood	20mm

**ID ED16A** 

**ELECTRIC DRILL**



Part No.: 21693

Rated Power Input	800w
No Load Speed	0-680r/min
Max. Drilling Diameter	
Steel	16mm
Wood	36mm

**ID ED16HQ** 

**ELECTRIC DRILL**



Part No.: 26537

Rated Power Input	800w
No Load Speed	0-680r/min
Max. Drilling Diameter	
Steel	16mm
Wood	36mm

►► **ANGLE DRILL**

**ID AD06-10**   
**ANGLE DRILL**



Part No.: 21629

Rated Power Input	380w
No Load Speed	0-1400r/min
Max. Drilling Diameter	
Steel	10mm
Wood	15mm



►► **IMPACT DRILL**

**ID EID03-13**   
**IMPACT DRILL**



Part No.: 26477

Rated Power Input	600w
No Load Speed	0-1450r/min
Max. Drilling Diameter	
Steel	13mm
Wood	20mm

**ID EID13**   
**IMPACT DRILL**



Part No.: 20239

Rated Power Input	600w
No Load Speed	0-1800r/min
Max. Drilling Diameter	
Steel	13mm
Wood	18mm

**ID 704RE**   
**IMPACT DRILL**



Part No.: 26773

Rated Power Input	650w
No Load Speed	0-2800r/min
Max. Drilling Diameter	
Steel	13mm
Wood	20mm

**ID EID13RF**   
**IMPACT DRILL**



Part No.: 27827

Rated Power Input	750w
No Load Speed	0-1800r/min
Max. Drilling Diameter	
Steel	13mm
Wood	20mm

**ID ID16VR**   
**IMPACT DRILL**



Part No.: 26028

Rated Power Input	750w
No Load Speed	0-2800r/min
Max. Drilling Diameter	
Steel	13mm
Wood	18mm

**ID ID13RF**   
**IMPACT DRILL**

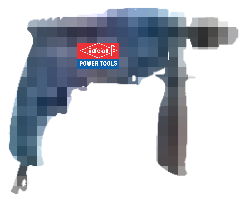

Part No.: 20258

Rated Power Input	750w
No Load Speed	0-2800r/min
Max. Drilling Diameter	
Steel	13mm
Wood	18mm

**ID PSB570VR**   
**IMPACT DRILL**



Part No.: 26960

Rated Power Input	650w
No Load Speed	0-2600r/min
Max. Drilling Diameter	
Steel	10mm
Wood	25mm
Concrete	13mm

**ID 850RF**   
**IMPACT DRILL**



Part No.: 26695

Rated Power Input	850w
No Load Speed	0-2800r/min
Max. Drilling Diameter	
Steel	13mm
Wood	18mm

►► **IMPACT DRILL**

**ID 950RF**   
**IMPACT DRILL**



Part No.: 21626

Rated Power Input	950w
No Load Speed	0-2800r/min
Max. Drilling Diameter	
Steel	13mm
Wood	18mm

**ID GSB13RE**   
**IMPACT DRILL**



Part No.: 21729

Rated Power Input	950w
No Load Speed	0-2800r/min
Max. Drilling Diameter	
Steel	13mm
Wood	18mm

**ID HKGSB13**   
**IMPACT DRILL (TOOL KIT)**



Part No.: 26348

Rated Power Input	500w
No Load Speed	0-2600r/min
Max. Drilling Diameter	
Steel	10mm
Wood	25mm
Concrete	13mm



►► **ROTARY HAMMER**

**ID HDC02-20**   
**ROTARY HAMMER**

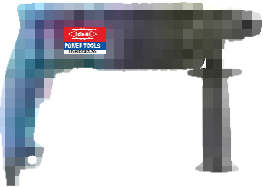

Part No.: 21738

Rated Power Input	500w
No Load Speed	0-850r/min
Max. Drilling Diameter	20mm

**ID HD2-20SE**   
**ROTARY HAMMER**



Part No.: 21737

Rated Power Input	500w
No Load Speed	0-850r/min
Max. Drilling Diameter	20mm

**ID RF20HK**   
**ROTARY HAMMER**



Part No.: 20277

Rated Power Input	500w
No Load Speed	0-850r/min
Max. Drilling Diameter	20mm

**ID HD2-24SE**   
**ROTARY HAMMER**



Part No.: 26732

Rated Power Input	620w
No Load Speed	0-870r/min
Max. Drilling Diameter	24mm

**ID HD2-26QC**   
**ROTARY HAMMER**



Part No.: 26229

Rated Power Input	800w
No Load Speed	0-900r/min
Max. Drilling Diameter	26mm

**ID HD2-26SE**   
**ROTARY HAMMER**



Part No.: 26733

Rated Power Input	800w
No Load Speed	0-900r/min
Max. Drilling Diameter	26mm

**ID RF26HK**   
**ROTARY HAMMER**



Part No.: 20278

Rated Power Input	800w
No Load Speed	0-900r/min
Max. Drilling Diameter	26mm

**ID HD2-28SE**   
**ROTARY HAMMER**



Part No.: 27592

Rated Power Input	800w
No Load Speed	0-1100r/min
Max. Drilling Diameter	28mm

► **ROTARY HAMMER**

**ID HD2-32QC**   
**ROTARY HAMMER**



Part No.: 27593

Rated Power Input	950w
No Load Speed	0-1300r/min
Max. Drilling Diameter	32mm

**ID HDC05-26B**   
**ROTARY HAMMER**



Part No.: 20253

Rated Power Input	720w
No Load Speed	0-1200r/min
Max. Drilling Diameter	26mm

**ID HDC03-26**   
**ROTARY HAMMER**



Part No.: 26478

Rated Power Input	750w
No Load Speed	0-500r/min
Max. Drilling Diameter	26mm

**ID GBH7DE**   
**ROTARY HAMMER**



Part No.: 26558

Rated Power Input	1100w
No Load Speed	0-320r/min
Max. Drilling Diameter	38mm

**ID RH38E**   
**ROTARY HAMMER**



Part No.: 20279

Rated Power Input	800w
No Load Speed	0-400r/min
Max. Drilling Diameter	38mm

**ID GSH388**   
**ROTARY HAMMER**



Part No.: 26694

Rated Power Input	1500w
No Load Speed	0-305r/min
Max. Drilling Diameter	45mm



►► **ANGLE GRINDER**

**ID DW8-100**  
**ANGLE GRINDER**



Part No.: 26809

Rated Power Input	850w
No Load Speed	0-13000r/min
Max. Wheel Diameter	100mm

**ID AG803**  
**ANGLE GRINDER**



Part No.: 26617

Rated Power Input	850w
No Load Speed	0-11000r/min
Max. Wheel Diameter	100mm

**ID DW803HQ**  
**ANGLE GRINDER**



Part No.: 26352

Rated Power Input	850w
No Load Speed	0-11000r/min
Max. Wheel Diameter	100mm

**ID AG801**  
**ANGLE GRINDER**



Part No.: 20220

Rated Power Input	850w
No Load Speed	0-11000r/min
Max. Wheel Diameter	100mm

**ID AG801N**  
**ANGLE GRINDER**



Part No.: 26724

Rated Power Input	850w
No Load Speed	0-11000r/min
Max. Wheel Diameter	100mm

**ID AGB100**  
**ANGLE GRINDER**



Part No.: 26958

Rated Power Input	710w
No Load Speed	0-13000r/min
Max. Wheel Diameter	100mm

**ID AG6-100HQ**  
**ANGLE GRINDER**



Part No.: 21637

Rated Power Input	710w
No Load Speed	0-11000r/min
Max. Wheel Diameter	100mm

**ID AG6-100**  
**ANGLE GRINDER**



Part No.: 21635

Rated Power Input	670w
No Load Speed	0-11000r/min
Max. Wheel Diameter	100mm

**ID AG100HQ**  
**ANGLE GRINDER**



Part No.: 27819

Rated Power Input	680w
No Load Speed	0-13000r/min
Max. Wheel Diameter	100mm

**ID AGH100**  
**ANGLE GRINDER**



Part No.: 26726

Rated Power Input	560w
No Load Speed	0-13000r/min
Max. Wheel Diameter	100mm

**ID AGH10-100V**  
**ANGLE GRINDER**



Part No.: 21631

Rated Power Input	1020w
No Load Speed	0-13000r/min
Max. Wheel Diameter	100mm

**ID GWS6-100HQ**  
**ANGLE GRINDER**



Part No.: 27820

Rated Power Input	710w
No Load Speed	0-13000r/min
Max. Wheel Diameter	110mm



►► **ANGLE GRINDER**

**ID PDM100**  
**ANGLE GRINDER**



Part No.: 21757

Rated Power Input	705w
No Load Speed	0-12000r/min
Max. Wheel Diameter	110mm

**ID G10SS**  
**ANGLE GRINDER**

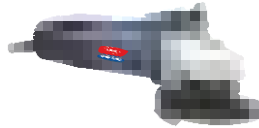

Part No.: 20246

Rated Power Input	650w
No Load Speed	0-11000r/min
Max. Wheel Diameter	110mm

**ID AG812**  
**ANGLE GRINDER**



Part No.: 26725

Rated Power Input	850w
No Load Speed	0-11000r/min
Max. Wheel Diameter	115mm

**ID AG812HQ**  
**ANGLE GRINDER**



**NEW**



Part No.: 27089

Rated Power Input	850w
No Load Speed	0-11000r/min
Max. Wheel Diameter	115mm

**ID AG115DC**  
**ANGLE GRINDER**



Part No.: 26014

Rated Power Input	750w
No Load Speed	0-11800r/min
Max. Wheel Diameter	115mm

**ID AGH125B**  
**ANGLE GRINDER**



Part No.: 26549

Rated Power Input	1200w
No Load Speed	0-11800r/min
Max. Wheel Diameter	125mm

**ID AG125NH**  
**ANGLE GRINDER**



**NEW**



Part No.: 27078

Rated Power Input	1200w
No Load Speed	0-11000r/min
Max. Wheel Diameter	125mm

**ID AG125HQ**  
**ANGLE GRINDER**



**NEW**



Part No.: 27816

Rated Power Input	1200w
No Load Speed	0-11800r/min
Max. Wheel Diameter	125mm

**ID AGH125**  
**ANGLE GRINDER**



Part No.: 21644

Rated Power Input	850w
No Load Speed	0-11800r/min
Max. Wheel Diameter	125mm

**ID AGH180**  
**ANGLE GRINDER**



Part No.: 26550

Rated Power Input	2200w
No Load Speed	0-8300r/min
Max. Wheel Diameter	180mm

**ID AGH230**  
**ANGLE GRINDER**



Part No.: 21645

Rated Power Input	2200w
No Load Speed	0-6600r/min
Max. Wheel Diameter	230mm

**ID GWS26-230H**  
**ANGLE GRINDER**



Part No.: 26547

Rated Power Input	2200w
No Load Speed	0-6600r/min
Max. Wheel Diameter	230mm

**ANGLE GRINDER  
DIE GRINDER / STRAIGHT GRINDER  
POWER CARVER**

*Ideally Advanced, Always!*

**▶▶ ANGLE GRINDER**

**ID 24-230DC  
ANGLE GRINDER**



Part No.: 21761

Rated Power Input	2200w
No Load Speed	0-6600r/min
Max. Wheel Diameter	230mm



**▶▶ DIE GRINDER**

**ID DG3  
DIE GRINDER**

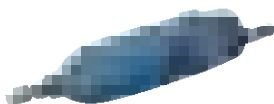

Part No.: 21681

Rated Power Input	105w
No Load Speed	0-30000r/min
Size Diameter	
G.W. Diameter	10mm
Collet Diameter	03mm

**ID DG6S  
DIE GRINDER**



Part No.: 26484

Rated Power Input	240w
No Load Speed	0-26000r/min
Size Diameter	
G.W. Diameter	25mm
Collet Diameter	06mm

**ID DG02-6  
DIE GRINDER**

**NEW**



Part No.: 26632

Rated Power Input	400w
No Load Speed	0-27000r/min
Size Diameter	
G.W. Diameter	25mm
Collet Diameter	03 & 06mm

**ID DG200  
DIE GRINDER**



Part No.: 21680

Rated Power Input	180w
No Load Speed	0-80000r/min
Size Diameter	
G.W. Diameter	10mm
Collet Diameter	03mm

**▶▶ STRAIGHT GRINDER / POWER CARVER**

**ID GQ125  
STRAIGHT GRINDER**

**NEW**



Part No.: 26561

Rated Power Input	710w
No Load Speed	0-5300r/min
Size Diameter	
G.W. Diameter	125mm

**ID GQ5HQ  
STRAIGHT GRINDER**



Part No.: 27817

Rated Power Input	710w
No Load Speed	0-5300r/min
Size Diameter	
G.W. Diameter	125mm

**ID HDG6  
POWER CARVER**

**NEW**



PEDAL OPERATED FLEXIBLE POWER CARVER Part No.: 20254

Rated Power Input	270w
No Load Speed	0-18000r/min
Chuck Capacity	0.3~4mm



►► **MARBLE CUTTER**

**ID SA03-110**   
**MARBLE CUTTER**



Part No.: 21761

Rated Power Input	1050w
No Load Speed	0-13300r/min
Max. Cutting Capacity	34mm
Blade Diameter	110/125mm

**ID CM4HQ**   
**MARBLE CUTTER**



Part No.: 21604

Rated Power Input	1050w
No Load Speed	0-13300r/min
Max. Cutting Capacity	34mm
Blade Diameter	110/125mm

**ID CM4SM**   
**MARBLE CUTTER**

**NEW**



Part No.: 20227

Rated Power Input	1100w
No Load Speed	0-13000r/min
Max. Cutting Capacity	34mm
Blade Diameter	110/125mm

**ID MC4**   
**MARBLE CUTTER**



Part No.: 20264

Rated Power Input	1050w
No Load Speed	0-12000r/min
Max. Cutting Capacity	34mm
Blade Diameter	110/125mm

**ID SB02-110**   
**MARBLE CUTTER**



Part No.: 26570

Rated Power Input	1240w
No Load Speed	0-12000r/min
Max. Cutting Capacity	34mm
Blade Diameter	110mm

**ID MC02-110HQ**   
**MARBLE CUTTER**

**NEW**



Part No.: 27958

Rated Power Input	1240w
No Load Speed	0-13000r/min
Max. Cutting Capacity	34mm
Blade Diameter	110mm

**ID MC04-110**   
**MARBLE CUTTER**



Part No.: 20263

Rated Power Input	1250w
No Load Speed	0-13000r/min
Max. Cutting Capacity	30mm
Blade Diameter	110mm

**ID SB02-110T**    
**MARBLE CUTTER**



Part No.: 26571

Rated Power Input	1240w
No Load Speed	0-13000r/min
Max. Cutting Capacity	30mm
Blade Diameter	110mm
Bevel Cutting Angle	0-45°

**ID MT410**    
**MARBLE CUTTER**

**NEW**



Part No.: 27815

Rated Power Input	1200w
No Load Speed	0-13000r/min
Max. Cutting Capacity	30mm
Blade Diameter	110mm
Bevel Cutting Angle	0-45°

**ID MT412**    
**MARBLE CUTTER**

**NEW**



Part No.: 21752

Rated Power Input	1300w
No Load Speed	0-13000r/min
Max. Cutting Capacity	34mm
Blade Diameter	110/125mm
Bevel Cutting Angle	0-45°

**ID MT525**    
**MARBLE CUTTER**

**NEW**



Part No.: 20270

Rated Power Input	1680w
No Load Speed	0-12000r/min
Max. Cutting Capacity	34mm
Blade Diameter	110/125mm
Bevel Cutting Angle	0-45°

**ID MT625**    
**MARBLE CUTTER**

**NEW**



Part No.: 26627

Rated Power Input	1300w
No Load Speed	0-12400r/min
Max. Cutting Capacity	38mm
Blade Diameter	110/125mm
Bevel Cutting Angle	0-45°

►► **MARBLE CUTTER**

**ID MT725**



**MARBLE CUTTER**



Part No.: 20272

Rated Power Input	1680w
No Load Speed	0-12000r/min
Max. Cutting Capacity	38mm
Blade Diameter	110/125mm
Bevel Cutting Angle	0-45°

**ID CM5SB**



**MARBLE CUTTER**



Part No.: 20228

Rated Power Input	1480w
No Load Speed	0-14000r/min
Max. Cutting Capacity	38mm
Blade Diameter	110/125mm
Bevel Cutting Angle	0-45°

**ID MC125H**



**MARBLE CUTTER**



Part No.: 21747

Rated Power Input	1400w
No Load Speed	0-13000r/min
Max. Cutting Capacity	38mm
Blade Diameter	110/125mm
Bevel Cutting Angle	0-45°

**ID GDC121**



**MARBLE CUTTER**

**NEW**



Part No.: 26378

Rated Power Input	1250w
No Load Speed	0-12000r/min
Max. Cutting Capacity	40mm
Blade Diameter	110/125mm

**ID MC6**



**MARBLE CUTTER**



Part No.: 21748

Rated Power Input	1050w
No Load Speed	0-7300r/min
Max. Cutting Capacity	50mm
Blade Diameter	150mm

**ID CM6HQ**



**MARBLE CUTTER**

**NEW**



Part No.: 26049

Rated Power Input	1420w
No Load Speed	0-11000r/min
Max. Cutting Capacity	50mm
Blade Diameter	150mm

**ID MC180HQ**



**MARBLE CUTTER**

**NEW**



Part No.: 27821

Rated Power Input	1520w
No Load Speed	0-5000r/min
Max. Cutting Capacity	50mm
Blade Diameter	180mm

**ID MCH180**



**MARBLE CUTTER**



Part No.: 26959

Rated Power Input	1520w
No Load Speed	0-5000r/min
Max. Cutting Capacity	60mm
Blade Diameter	180mm

►► **MANUAL TILE CUTTER**

**ID HTC24/36/48**

**TILE CUTTER**



Part No.: 23290/91/92

Vitrified Tile Cutter

ID HTC24	23290
ID HTC36	23291
ID HTC48	23292



►► **WALL CHASER / GROOVE CUTTER**

**ID GC135**   
**WALL CHASER**

**NEW**



Part No.: 26224

Rated Power Input	3000w
No Load Speed	0-5000r/min
Max. Cutting Capacity	42X41mm
Blade Diameter	135mm

**ID 2535**   
**WALL CHASER**



Part No.: 21614

Max. Cutting Capacity	35mm
High Quality Wall Chaser	

**ID GC110**   
**GROOVE CUTTER**



Part No.: 26559

Rated Power Input	1600w
No Load Speed	0-10800r/min
Max. Cutting Capacity	
Width	50mm
Depth	9mm



►► **SLAB CUTTER**

**ID CM12YSB**   
**SLAB CUTTER**



Part No.: 21673

Rated Power Input	2400w
No Load Speed	0-5000r/min
Max. Cutting Capacity	100mm
Blade Diameter	305mm
Bore Diameter	25.4mm

**ID CM14YSB**   
**SLAB CUTTER**



Part No.: 26347

Rated Power Input	2400w
No Load Speed	0-5000r/min
Max. Cutting Capacity	125mm
Blade Diameter	355mm
Bore Diameter	25.4mm

**ID CM14Y**   
**SLAB CUTTER**

**NEW**

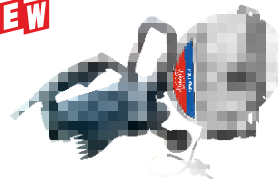

Part No.: 26771

Rated Power Input	4000w
No Load Speed	0-4800r/min
Max. Cutting Capacity	125mm
Blade Diameter	335mm
Bore Diameter	25.4mm



►► **DRILL STAND / GRINDER STAND / MINI BENCH DRILL**

**ID CDS13**  
**DRILL STAND**



Part No.: 23335

Max. Drill Depth	60mm
Column Height	32x400mm
Clamp Diameter	44mm

**ID DS13H**  
**DRILL STAND**



**PRECISE DRILL STAND** Part No.: 20354

Max. Drill Depth	60mm
Column Height	32x400mm
Clamp Diameter	44mm

**ID GS45C/GS7-9**  
**GRINDER STAND**



Part No.: 23336-38

23336 - Stand For	
4" & 5" Angle Grinder.	
23338 - Steel, 23337 - Alu.	
Stand For	
7" & 9" Angle Grinder.	

**ID BDS13**   
**MINI BENCH DRILL**

**NEW**



Part No.: 26627

Rated Power Input	1050w
Max. Cutting Capacity	140mm
Max. Drilling Diameter	
Wood	35mm
Iron	140mm

►► **CUT-OFF SAW**

**ID CO205**



**CUT-OFF SAW**

**NEW**



Part No.: 26811

Rated Power Input	1200w
No Load Speed	0-3800r/min
Max. Wheel Diameter	205mm(8")
Mitre Cutting Angle	0-45°

**ID DCO355**



**CUT-OFF SAW**



Part No.: 26552

Rated Power Input	1800w
No Load Speed	0-3800r/min
Max. Wheel Diameter	355mm(14")
Mitre Cutting Angle	0-45°

**ID CO2200**



**CUT-OFF SAW**



Part No.: 26772

Rated Power Input	2200w
No Load Speed	0-3800r/min
Max. Wheel Diameter	355mm(14")
Mitre Cutting Angle	0-45°

**ID CO355HQ**



**CUT-OFF SAW**



Part No.: 21678

Rated Power Input	2200w
No Load Speed	0-3800r/min
Max. Wheel Diameter	355mm(14")
Mitre Cutting Angle	0-45°

**ID 2414NB**



**CUT-OFF SAW**



Part No.: 21613

Rated Power Input	2000w
No Load Speed	0-3800r/min
Max. Wheel Diameter	355mm(14")
Mitre Cutting Angle	0-45°

**ID DCO14-2**



**CUT-OFF SAW**



Part No.: 20229

Rated Power Input	2100w
No Load Speed	0-3800r/min
Max. Wheel Diameter	355mm(14")
Mitre Cutting Angle	0-45°

**ID CC14SM**



**CUT-OFF SAW**



Part No.: 21657

Rated Power Input	2000w
No Load Speed	0-3800r/min
Max. Wheel Diameter	355mm(14")
Mitre Cutting Angle	0-45°

**ID 7614NB**



**CUT-OFF SAW**



Part No.: 26578

Rated Power Input	2300w
No Load Speed	0-3800r/min
Max. Wheel Diameter	355mm(14")
Mitre Cutting Angle	0-45°

**ID GCO400B**

**CUT-OFF SAW**

**NEW**



MOTORISED  
CUT-OFF SAW

Part No.: 27371

Rated Power Input	2200w
No Load Speed	0-2480r/min
Max. Wheel Diameter	400mm(16")
Mitre Cutting Angle	0-45°



► **MITRE SAW**

**ID MSM255**



**MITRE SAW**

**NEW**



Part No.: 26566

Rated Power Input	1650w
No Load Speed	0-4600r/min
Max. Wheel Diameter	255mm(10")
Mitre Cutting Angle	0-45°
Bevel Cutting Angle	0-45°

**ID DW873**



**MITRE SAW**



Part No.: 21687

Rated Power Input	1800w
No Load Speed	0-6000r/min
Max. Wheel Diameter	255mm(10")
Mitre Cutting Angle	0-45°
Bevel Cutting Angle	0-45°

**ID LS1040**



**MITRE SAW**



Part No.: 20262

Rated Power Input	1650w
No Load Speed	0-5000r/min
Max. Wheel Diameter	255mm(10")
Mitre Cutting Angle	0-45°
Bevel Cutting Angle	0-45°

**ID LS1050D**



**MITRE SAW**

**NEW**



Part No.: 26432

Rated Power Input	1800w
No Load Speed	0-6000r/min
Max. Wheel Diameter	255mm(10")
Mitre Cutting Angle	0-45°
Bevel Cutting Angle	0-45°

**ID MS255[S]**



**MITRE SAW**

**NEW**



**SLIDING MITRE SAW** Part No.: 20267

Rated Power Input	1900w
No Load Speed	0-4500r/min
Max. Wheel Diameter	255mm(10")
Mitre Cutting Angle	0-45°
Bevel Cutting Angle	0-45°

**ID MS305**



**MITRE SAW**



**MITRE SAW BIG SIZE BASE** Part No.: 26566

Rated Power Input	1800w
No Load Speed	0-5000r/min
Max. Wheel Diameter	305mm(12")
Mitre Cutting Angle	0-45°
Bevel Cutting Angle	0-45°

**ID MS355**



**MITRE SAW**

**NEW**



**MITRE SAW BIG SIZE BASE** Part No.: 21751

Rated Power Input	2000w
No Load Speed	0-3500r/min
Max. Wheel Diameter	355mm(14")
Mitre Cutting Angle	0-45°
Bevel Cutting Angle	0-45°



**► DEMOLITION HAMMER**

**ID HM810S**   
**DEMOLITION HAMMER**



Part No.: 26491

Rated Power Input	1050w
Rated Impacting	2900./min
Weight	5kg

**ID HM810T**   
**DEMOLITION HAMMER**



Part No.: 26476

Rated Power Input	1050w
Rated Impacting	2900./min
Weight	5kg

**ID HM1201HQ**   
**DEMOLITION HAMMER**



Part No.: 21741

Rated Power Input	1350w
Rated Impacting	2300./min
Weight	10.3kg

**ID DL810M**   
**DEMOLITION HAMMER**



Part No.: 26048

Rated Power Input	1050w
Rated Impacting	2900./min
Weight	5kg

**ID MX810T**   
**DEMOLITION HAMMER**



Part No.: 26031

Rated Power Input	1350w
Rated Impacting	3900./min

**ID 820THQ**   
**DEMOLITION HAMMER**



Part No.: 26579

Rated Power Input	1100w
Rated Impacting	2900./min
Weight	5.5kg

**ID DL820T**   
**DEMOLITION HAMMER**



Part No.: 26884

Rated Power Input	1100w
Rated Impacting	2900./min

**ID 0835T**   
**DEMOLITION HAMMER**



Part No.: 27583

Rated Power Input	2000w
Rated Impacting	3200./min
Weight	9.8kg

**ID 0850T**   
**DEMOLITION HAMMER**



Part No.: 26011

Rated Power Input	1050w
Rated Impacting	3000./min

**ID GDC11E**   
**DEMOLITION HAMMER**



Part No.: 26560

Rated Power Input	1500w
Rated Impacting	18900./min
Weight	11kg

**ID HQ11E**   
**DEMOLITION HAMMER**



Part No.: 26563

Rated Power Input	1500w
Rated Impacting	2000./min
Weight	11kg

**ID GSH11E**   
**DEMOLITION HAMMER**



Part No.: 26095

Rated Power Input	1500w
Rated Impacting	2000./min
Weight	11kg



► **DEMOLITION HAMMER**

**ID GBH11DE**   
**DEMOLITION HAMMER**

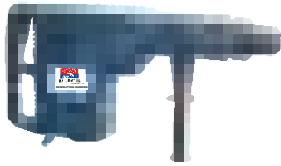

Part No.: 21718

Rated Power Input	1500w
Rated Impacting	1890./min
Weight	11kg
Max. Capacity	50mm

**ID PH65A**   
**DEMOLITION HAMMER**



Part No.: 26999

Rated Power Input	1200w
Rated Impacting	1400./min
Rated Power Capacity	45J
Weight	11kg

**ID PH65M**   
**DEMOLITION HAMMER**

**NEW**



Part No.: 21759

Rated Power Input	1200w
Rated Impacting	1400./min
Rated Power Capacity	45J
Weight	11kg

**ID PH65HC**   
**DEMOLITION HAMMER**

**NEW**



Part No.: 26350

Rated Power Input	1010w
Rated Impacting	1300./min
Rated Power Capacity	45J
Weight	16kg

**ID PH65HD**   
**DEMOLITION HAMMER**



Part No.: 26535

Rated Power Input	1240w
Rated Impacting	1300./min
Rated Power Capacity	45J
Weight	16.0kg

**ID GSH16-30**   
**DEMOLITION HAMMER**



Part No.: 21730

Rated Power Input	1700w
Rated Impacting	2900./min
Weight	16.5kg

**ID GSH16-50**   
**DEMOLITION HAMMER**

**NEW**



Part No.: 26704

Rated Power Input	1700w
Rated Impacting	2900./min
Weight	16.5kg

Anti - Kick Back



**►► CORE DRILL**

**ID CDC90  
CORE DRILL**



Part No.: 26353

Rated Power Input	1350w
No Load Speed	0-2300r/min
Max. Drilling Diameter	90mm

**ID CDC110  
CORE DRILL**



Part No.: 21662

Rated Power Input	1800w
No Load Speed	0-2000r/min
Max. Drilling Diameter	110mm

**ID CDC130H  
CORE DRILL**



Part No.: 21663

Rated Power Input	1800w
No Load Speed	0-1200r/min
Max. Drilling Diameter	130mm

**ID CDC200S  
CORE DRILL**



Part No.: 26483

Rated Power Input	3300w
No Load Speed	0-500r/min
Max. Drilling Diameter	200mm

**ID CDG250  
CORE DRILL**



Part No.: 26551

Rated Power Input	3800w
No Load Speed	0-1100r/min
Max. Drilling Diameter	250mm

**ID CG280  
CORE DRILL**



**NEW**



Part No.: 20225

Rated Power Input	3750w
No Load Speed	0-4000r/min
Max. Drilling Diameter	280mm



**►► CONCRETE MIXER**

**ID CM210C  
CONCRETE MIXER**

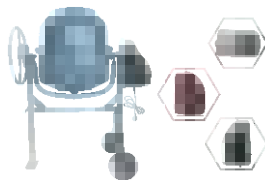

**GEAR TYPE  
CONCRETE MIXER** Part No.: 21675

Rated Power Input	850w
No Load Speed	0-2800r/min
Drum Capacity	180L
Drum Speed	28r/min

**ID CM200B  
CONCRETE MIXER**



**BARROW TYPE  
CONCRETE MIXER** Part No.: 21674

Rated Power Input	850w
No Load Speed	0-2800r/min
Drum Capacity	180L
Drum Speed	30r/min



►► **CONCRETE VIBRATOR**

**ID VR850**   
**CONCRETE VIBRATOR**



Part No.: 21778

Rated Power Input	850w
No Load Speed	0-4000r/min
Dia. of Vibrating Shaft	35mm

**ID VR860**   
**CONCRETE VIBRATOR**

**NEW**



Part No.: 20285

Rated Power Input	860w
No Load Speed	0-5000r/min
Dia. of Vibrating Shaft	35mm

**ID VR900**   
**CONCRETE VIBRATOR**



Part No.: 20284

Rated Power Input	900w
No Load Speed	0-5000r/min
Dia. of Vibrating Shaft	35mm

**ID VR1000**   
**CONCRETE VIBRATOR**

**NEW**



Part No.: 26032

Rated Power Input	1200w
No Load Speed	0-5000r/min
Dia. of Vibrating Shaft	35-60mm

**ID VR2250M**   
**CONCRETE VIBRATOR**

**NEW**



Part No.: 26495

Rated Power Input	2250w
No Load Speed	0-4000r/min
Dia. of Vibrating Shaft	35-60mm

Can Be Use 3 Mtr Shaft

**ID VR1600**   
**CONCRETE VIBRATOR**



Part No.: 21774

Rated Power Input	1600w
No Load Speed	0-4000r/min
Dia. of Vibrating Shaft	50mm

**ID VR2000**   
**CONCRETE VIBRATOR**



Part No.: 21775

Rated Power Input	2000w
No Load Speed	0-4000r/min
Dia. of Vibrating Shaft	50mm

**ID VR2HP**   
**CONCRETE VIBRATOR**

**NEW**



Part No.: 21776

Rated Power Input	1500w
No Load Speed	2HP
Dia. of Vibrating Shaft	35-60mm

►► **VIBRATOR SHAFT**

**ID SHAFT**   
**VIBRATOR SHAFT**



**CONCRETE VIBRATOR SHAFT**

ID FS1M	1Mx35MM	20344
ID FS1.5M	1.5Mx35MM	26382
ID FS2M	2Mx35MM	20345
ID FS3M	3Mx35MM	20346
ID FS4M	4Mx35MM	26829
ID FS12M	12Mx50MM	23164



►► **CIRCULAR SAW**

**ID C7**



**CIRCULAR SAW**



Part No.: 26731

Rated Power Input	1050w
No Load Speed	0-5000r/min
Max. Cutting Capacity	64mm
Max. Cutting Angle	45°

**ID C7SC**



**CIRCULAR SAW**



Part No.: 21656

Rated Power Input	1100w
No Load Speed	0-4800r/min
Max. Cutting Capacity	64mm
Max. Cutting Angle	45°

**ID WCS185**



**CIRCULAR SAW**



Part No.: 26482

Rated Power Input	1100w
No Load Speed	0-4900r/min
Max. Cutting Capacity	64mm
Max. Cutting Angle	45°

**ID WCS180**



**CIRCULAR SAW**

**NEW**



Part No.: 20286

Rated Power Input	1100w
No Load Speed	0-5600r/min
Max. Cutting Capacity	64mm
Max. Cutting Angle	45°

**ID WCS230**



**CIRCULAR SAW**

**NEW**



Part No.: 27184

Rated Power Input	2300w
No Load Speed	0-4000r/min
Max. Blade Diameter	235mm
Max. Cutting Capacity	84mm
Max. Cutting Angle	45°

**ID WCS235**



**CIRCULAR SAW**

**NEW**



Part No.: 26481

Rated Power Input	1520w
No Load Speed	0-4100r/min
Max. Cutting Capacity	84mm
Max. Cutting Angle	45°

**ID WCS255**



**CIRCULAR SAW**

**NEW**



Part No.: 27283

Rated Power Input	2300w
No Load Speed	0-4200r/min
Max. Blade Diameter	255mm
Max. Cutting Capacity	84mm
Max. Cutting Angle	45°

**ID WCS305**



**CIRCULAR SAW**

**NEW**



Part No.: 20289

Rated Power Input	2300w
No Load Speed	0-3700r/min
Max. Blade Diameter	305mm
Max. Cutting Capacity	84mm
Max. Cutting Angle	45°

**ID WCS350**



**CIRCULAR SAW**

**NEW**



Part No.: 27183

Rated Power Input	2400w
No Load Speed	0-3300r/min
Max. Blade Diameter	350mm
Max. Cutting Capacity	157mm
Max. Cutting Angle	45°

**ID N5900DC**



**CIRCULAR SAW**



Part No.: 27227

Rated Power Input	2000w
No Load Speed	0-4100r/min
Max. Blade Diameter	235mm
Max. Cutting Capacity	85
Max. Cutting Angle	45°



►► **WOOD ROUTER**

**ID WR8E**   
**WOOD ROUTER**



Part No.: 21779

Rated Power Input	900w
No Load Speed	0-26000r/min
Collet Chuck Capacity	8mm

**ID WR12E**   
**WOOD ROUER**



Part No.: 26572

Rated Power Input	1600w
No Load Speed	0-23000r/min
Collet Chuck Capacity	8-12.7mm

**ID WR12HQ**   
**WOOD ROUER**

**NEW**



Part No.: 26536

Rated Power Input	1650w
No Load Speed	0-22000r/min
Collet Chuck Capacity	8-12.7mm

**ID WR12G**   
**WOOD ROUER**

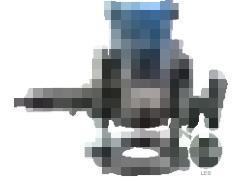

Part No.: 20291

Rated Power Input	1850w
No Load Speed	0-23000r/min
Collet Chuck Capacity	8-12.7mm

►► **WOOD ROUTER / JIG SAW**

**ID 3712SH**   
**WOOD ROUTER**



Part No.: 26007

Rated Power Input	1650w
No Load Speed	0-22000r/min
Collet Chuck Capacity	8-12.7mm



**ID JDC65**   
**JIG SAW**



Part No.: 26564

Rated Power Input	580w
No Load Speed	0-3100r/min
Max. Cutting Capacity	
Steel	10mm
Wood	65mm
Bevel Cutting Angle	45°

**ID GST80**   
**JIG SAW**

**NEW**



Part No.: 26024

Rated Power Input	580w
No Load Speed	0-3100r/min
Max. Cutting Capacity	
Steel	10mm
Wood	80mm
Bevel Cutting Angle	45°

►► **JIG SAW**

**ID JDC85**   
**JIG SAW**



Part No.: 26565

Rated Power Input	580w
No Load Speed	0-3100r/min
Max. Cutting Capacity	
Steel	10mm
Wood	85mm
Bevel Cutting Angle	45°

**ID 633S**   
**JIG SAW**



Part No.: 20219

Rated Power Input	580w
No Load Speed	0-3100r/min
Max. Cutting Capacity	
Steel	10mm
Wood	70mm
Bevel Cutting Angle	45°



► **ELECTRIC PLANER**

**ID EP82X1**   
**ELECTRIC PLANER**

**NEW**



Part No.: 27182

Rated Power Input	500w
No Load Speed	0-16000r/min
Max. Planning Width	82mm
Max. Planning Depth	1mm

**ID EP82X2**   
**ELECTRIC PLANER**



Part No.: 26557

Rated Power Input	500w
No Load Speed	0-16000r/min
Max. Planning Width	82mm
Max. Planning Depth	1mm

**ID EP82DC**   
**ELECTRIC PLANER**



Part No.: 26022

Rated Power Input	500w
No Load Speed	0-16000r/min
Max. Planning Width	82mm
Max. Planning Depth	1mm

**ID EP82HQ**   
**ELECTRIC PLANER**



Part No.: 26356

Rated Power Input	500w
No Load Speed	0-16000r/min
Max. Planning Width	82mm
Max. Planning Depth	1mm

**ID GH082-2**   
**ELECTRIC PLANER**

**NEW**



Part No.: 27075

Rated Power Input	560w
No Load Speed	0-16000r/min
Max. Planning Width	82mm
Max. Planning Depth	1mm

**ID EP82HD**   
**ELECTRIC PLANER**



Part No.: 21706

Rated Power Input	700w
No Load Speed	0-16000r/min
Max. Planning Width	82mm
Max. Planning Depth	1mm

**ID EP90M**   
**ELECTRIC PLANER**



Part No.: 21707

Rated Power Input	850w
No Load Speed	0-16000r/min
Max. Planning Width	90mm
Max. Planning Depth	2mm

**ID EP110X2**   
**ELECTRIC PLANER**



Part No.: 26556

Rated Power Input	840w
No Load Speed	0-16500r/min
Max. Planning Width	110mm
Max. Planning Depth	2mm



►► **WOOD TRIMMER / RECIPROCATING SAW**

**ID WTM6**   
**WOOD TRIMMER**



Part No.: 26355

Rated Power Input	350w
No Load Speed	0-3000r/min
Collet Chuck Capacity	6/6.35mm

**ID WT6HQ**   
**WOOD TRIMMER**

**NEW**



Part No.: 26026

Rated Power Input	350w
No Load Speed	0-3000r/min
Collet Chuck Capacity	6/6.5mm

**ID GWT6**   
**WOOD TRIMMER**

**NEW**



Part No.: 26480

Rated Power Input	550w
No Load Speed	0-30000r/min
Collet Chuck Capacity	6/6.5mm

**ID RS30**    
**RECIPROCATING SAW**



Part No.: 26197

Rated Power Input	500w
No Load Speed	0-2300r/min
Length of Strokes	30mm
Max. Cutting Capacity	90mm

►► **ELECTRIC TACKER / AIR NAILER**

**ID GT13**   
**ELECTRIC TACKER**



Part No.: 23371

Rated Power Input	2000w
No Load Speed	20Pcs/min
Staple Spec.(Type 53)	L=8-16mm
Brad Nail Spec.(Type 53)	L=15-16mm

**ID ANF50**  
**AIR NAILER**



Part No.: 27614

Rated Power Input	70-100PSI
	4.8-7.5Bar
Max. Pressure	120PSI
	8.3Bar
Weight	1.4kg
	3.0lb



**ELECTRIC CHAIN SAW  
GASOLINE CHAIN SAW  
CHAIN SAW CHAIN / GUIDE BAR**

*Ideally Advanced, Always!*

**▶▶ ELECTRIC CHAIN SAW**

**ID ES405N**   
**ELECTRIC CHAIN SAW**



Part No.: 21708

Rated Power Input	1650w
No Load Speed	0-4000r/min
Guide Bar Length	405mm
Can Be Use	18"/22"

With Change The Bar & Chain

**ID ES505N**   
**ELECTRIC CHAIN SAW**

**NEW**



Part No.: 27842

Rated Power Input	2200w
No Load Speed	0-4000r/min
Guide Bar Length	555mm
Can Be Use	18"/22"

With Change The Bar & Chain



**▶▶ GASOLINE CHAIN SAW**

**ID 5800**   
**GASOLINE CHAIN SAW**

**NEW**

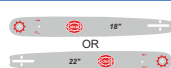

Part No.: 27959

Rated Power Input	3.5kw
No Load Speed	0-11000r/min
Guide Bar Length	455/560mm
Rated Power Capacity	58cc

Guide Bar : 18" & 22"(Optional)

**ID 6200**   
**GASOLINE CHAIN SAW**

**NEW**



Part No.: 27960

Rated Power Input	3.5kw
No Load Speed	0-11000r/min
Guide Bar Length	455/560mm
Rated Power Capacity	62cc

Guide Bar : 18" & 22"(Optional)

**ID 58HQ**   
**GASOLINE CHAIN SAW**

**NEW**

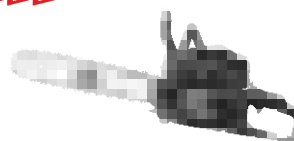

Part No.: 21624

Rated Power Input	3.5kw
No Load Speed	0-11000r/min
Guide Bar Length	560mm
Rated Power Capacity	58cc

Guide Bar : 18" & 22"(Optional)

**ID 62HQ**   
**GASOLINE CHAIN SAW**

**NEW**



Part No.: 27234

Rated Power Input	2.6w
No Load Speed	0-3000r/min
Guide Bar Length	560mm
Rated Power Capacity	62cc

Guide Bar : 18" & 22"(Optional)

**▶▶ SAW CHAIN / GUIDE BAR**

**ID SAW CHAIN**  
**CHAIN SAW CHAIN**

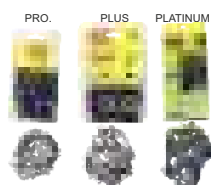

16" 18" 22"

Ideal Professional  
Ideal Plus  
Ideal Platinum

**ID GUIDE BAR**  
**SAW GUIDE BAR**

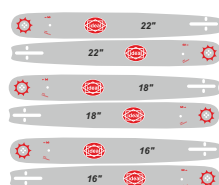

CHAINSAW GUIDE BAR

GUIDE BAR FOR CHAIN SAW  
SIZE: 16',18",22"





► **BRUSH CUTTER**

**ID BC280  
BRUSH CUTTER**



Part No.: 21601

Engine Capacity	52cc
Fuel Tank Capacity	1l
Stroke	2

**ID BC802S  
BRUSH CUTTER**



Part No.: 20223

Engine Capacity	52cc
Fuel Tank Capacity	1l
Stroke	2

**ID BC804S  
BRUSH CUTTER**



Part No.: 21648

Engine Capacity	52cc
Fuel Tank Capacity	1l
Stroke	2

**ID BCB85  
BRUSH CUTTER**



Part No.: 21649

Engine Capacity	35cc
Fuel Tank Capacity	1l
Stroke	2

**ID BC584S  
BRUSH CUTTER**

**NEW**



(BAG PACK)  
BRUSH CUTTER

Part No.: 26826

Engine Capacity	35cc
Fuel Tank Capacity	1l
Stroke	2



► **AUGER DRILL MACHINE / LAWN MOVER / HEDGE TRIMMER / POWER TILLER**

**ID AD600  
AUGER DRILL MACHINE**



Part No.: 21602

Rated Power Input	1700w
Engine Capacity	52cc
Fuel Ratio	1:25

Auger Drill Bit Size Available	100mm, 150mm, 200mm, 250mm, 300mm
--------------------------------	-----------------------------------

**ID LM1800  
LAWN MOVER**



GASOLINE  
LAWN MOVER

Part No.: 21606

Rated Power Input	8.1Nm
No Load Speed	3000r/min
Width of Cut	480mm
Blade Type	Flail Knife

**ID HT400  
HEDGE TRIMMER**

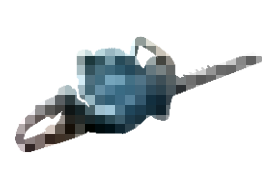

Part No.: 21605

Rated Power Input	0.7w
No Load Speed	7500r/min
Engine Capacity	22.5cc
Width of Cut	600mm
Blade Type	Double-edge Tooth

**ID PT24  
POWER TILLER**



GASOLINE  
POWER TILLER

Part No.: 21607

Rated Power Input	0.7w
No Load Speed	7500r/min
Engine Capacity	22.5cc
Width of Cut	600mm
Blade Type	Double-edge Tooth

► **PETROL GENERATOR**

**ID PG1200**

**PETROL GENERATOR**



Part No.: 26317

Rated Power	0.8kw
Max. Power	0.9kw
Phase	SINGLE
Engine Model	154FAE
Starting Type	RECOIL Starter

**ID PG1500S**

**PETROL GENERATOR**



Part No.: 26318

AC Rated Power	0.9kw
Phase	1.0kw
Rated Welding Current	SINGLE
Engine Model	154FAE
Starting Type	Self-Starter With Battery

**ID PG3600**

**PETROL GENERATOR**



Part No.: 26349

Rated Power	2.8kw
Max. Power	3.0kw
Phase	SINGLE
Engine Model	170F
Starting Type	RECOIL Starter

**ID PG3605S**

**PETROL GENERATOR**



Part No.: 26319

Rated Power	2.8kw
Max. Power	3.0kw
Phase	SINGLE
Engine Model	170FE
Starting Type	Self-Starter With Battery

► **PETROL GENERATOR / DIESEL GENERATOR**

**ID PG6500S**

**PETROL GENERATOR**



Part No.: 26320

Rated Power	5.0kw
Max. Power	5.5kw
Phase	SINGLE
Engine Model	188FE
Starting Type	Self-Starter With Battery

**ID PG9500S**

**PETROL GENERATOR**



Part No.: 26321

AC Rated Power	7.0kw
Phase	7.5kw
Rated Welding Current	SINGLE
Engine Model	192FE
Starting Type	Self-Starter With Battery

**ID DG6510S**

**DIESEL GENERATOR**



Part No.: 26323

Max. Power	5.0kw
Phase	SINGLE
Fuel Tank Capacity	13L
Engine Model	186FE
Starting Type	Self-Starter With Battery

**ID DG8510S**

**DIESEL GENERATOR**



Part No.: 26324

Max. Power	8.8kw
Phase	SINGLE
Fuel Tank Capacity	13L
Engine Model	192FAE
Starting Type	Self-Starter With Battery

► **WELDING GENERATOR**

**ID PG200A**

**WELDING GENERATOR**



Part No.: 26322

AC Rated Power	5.0kw
Phase	SINGLE
Rated Welding Current	200
Engine Model	192FE
Starting Type	Self-Starter With Battery



**▶▶ GASOLINE WATER PUMP**

**ID PW38  
WATER PUMP**



**GASOLINE WATER PUMP** Part No.: 26326

Max. Output of Engine	7.5HP
Inlet / Outlet Size	38mm(1-1.5")
Rated Self-Suction	5m(Max. 8m)
Engine Model	170F

**ID PW50  
WATER PUMP**



**GASOLINE WATER PUMP** Part No.: 26325

Max. Output of Engine	7.5HP
Inlet / Outlet Size	50mm(2")
Rated Self-Suction	5m(Max. 8m)
Engine Model	170F

**ID PW80  
WATER PUMP**



**GASOLINE WATER PUMP** Part No.: 26327

Max. Output of Engine	7.5HP
Inlet / Outlet Size	80(3")
Rated Self-Suction	5m(Max. 8m)
Engine Model	170F

**ID PW100  
WATER PUMP**



**GASOLINE WATER PUMP** Part No.: 27148

Max. Output of Engine	7.5HP
Inlet / Outlet Size	100mm(4")
Rated Self-Suction	5m(Max. 8m)
Engine Model	170F

**▶▶ GASOLINE ENGINE**

**ID PEW170  
GASOLINE ENGINE**



Part No.: 27594

Max. Power	7.0HP
Engine Capacity	212CC
Compression Ratio	8.2:1
Oil Capacity	0.6L
Fuel Tank Capacity	3.6L



**▶▶ ORBITAL SANDER / FLAT SANDER**

**ID OS100  
ORBITAL SANDER**



Part No.: 26567

Rated Power Input	150w
No Load Speed	12000r/min
Pad Size	100x110mm

**ID OS185  
ORBITAL SANDER**



Part No.: 26568

Rated Power Input	180w
No Load Speed	10000r/min
Pad Size	93x185mm

**ID OS234  
FLAT SANDER**



Part No.: 26569

Rated Power Input	520w
No Load Speed	10000r/min
Pad Size	114x234mm

**ID FS210AC  
FLAT SANDER**



Part No.: 21716

Rated Power Input	200w
No Load Speed	7200r/min
Pad Size	110x210mm

Induction Motor Type

**▶▶ ROTARY SANDER/ BELT SANDER/ DISC POLISHER**

**ID GEX150H**   
**ROTARY SANDER**



Part No.: 21726

Rated Power Input	430w
No Load Speed	13000r/min
Max. Disc Diameter	150mm

**ID PEX125**   
**ROTARY SANDER**



Part No.: 26310

Rated Power Input	300w
No Load Speed	12000r/min
Max. Disc Diameter	125mm

**ID BS610**   
**BELT SANDER**



Part No.: 21655

Rated Power Input	1200w
Belt Speed	500r/min
Belt Size	100x610mm

**ID DS150**   
**DISC SANDER**



Part No.: 21682

Rated Power Input	405w
No Load Speed	4700r/min
Max. Disc Diameter	150mm

**▶▶ ELECTRIC SANDER POLISHER**

**ID DSP180**   
**SANDER POLISHER**



**ELECTRIC SANDER POLISHER** Part No.: 26553

Rated Power Input	750w
No Load Speed	3200r/min
Max. Disc Diameter	180mm

**ID DSP03-180**   
**SANDER POLISHER**

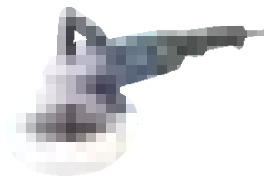

**ELECTRIC SANDER POLISHER** Part No.: 21683

Rated Power Input	1020w
No Load Speed	3600r/min
Max. Disc Diameter	180mm

**ID SP180FC**   
**SANDER POLISHER**

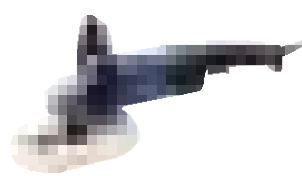

**ELECTRIC SANDER POLISHER** Part No.: 21767

Rated Power Input	1200w
No Load Speed	3000r/min
Max. Disc Diameter	180mm

**ID SP180C**   
**SANDER POLISHER**



**ELECTRIC SANDER POLISHER** Part No.: 27851

Rated Power Input	1200w
No Load Speed	2300r/min
Max. Disc Diameter	180mm

**ID GPS100**   
**SANDER POLISHER**



**ELECTRIC SANDER POLISHER** Part No.: 26479

Rated Power Input	1400w
No Load Speed	3800r/min
Max. Disc Diameter	120x100mm



►► **AIR BLOWER**

**ID BL1100**



**AIR BLOWER**



Part No.: 26569

Rated Power Input	500w
No Load Speed	0-13000r/min
Air Circulation	2.3m <sup>3</sup> /min

**ID GBL25**



**AIR BLOWER**



Part No.: 21721

Rated Power Input	4800w
No Load Speed	0-14000r/min
Air Circulation	2.5m <sup>3</sup> /min

**ID GBL32**



**AIR BLOWER**



Part No.: 21722

Rated Power Input	680w
No Load Speed	0-16300r/min
Air Circulation	3.2m <sup>3</sup> /min

**ID EBC40V**



**AIR BLOWER**



Part No.: 21688

Rated Power Input	550w
No Load Speed	0-13000r/min
Air Circulation	2.3m <sup>3</sup> /min

**ID EBC44**



**AIR BLOWER**

**NEW**



Part No.: 26198

Rated Power Input	840w
No Load Speed	0-15000r/min
Air Circulation	2.8m <sup>3</sup> /min

**ID GBL16VC**



**AIR BLOWER**



Part No.: 21720

Rated Power Input	840w
No Load Speed	0-15000r/min
Air Circulation	2.8m <sup>3</sup> /min

**ID GBL38SA**



**AIR BLOWER**

**NEW**



Part No.: 27074

Rated Power Input	850w
No Load Speed	0-16000r/min
Air Circulation	2.8m <sup>3</sup> /min

**ID GBL40SA**



**AIR BLOWER**



Part No.: 20248

Rated Power Input	600w
No Load Speed	0-16000r/min
Air Circulation	2.8m <sup>3</sup> /min

►► **HEAT GUN / CHAIN SHARPENER**

**ID HG2000**



**HEAT GUN**



Part No.: 26562

Rated Power Input	2000w
Temp. Low	50-480°C
Temp. High	50-600°C
Air Flow(Low Temp.)	210-250l/min
Air Flow(High Temp.)	340-380l/min

**ID HAG2200**



**HEAT GUN**



Part No.: 21734

Rated Power Input	2000w
Temp. Low	50-480°C
Temp. High	50-600°C
Air Flow(Low Temp.)	210-250l/min
Air Flow(High Temp.)	340-380l/min

**ID CS100**



**CHAIN SHARPENER**

**NEW**



Part No.: 27932

Rated Power Input	180w
No Load Speed	6300r/min
Max. Disc Diameter	100mm



► **VACUUM CLEANER**

**ID HVC15**   
**VACUUM CLEANER**



Part No.: 26582

Rated Power Input	1200w
Capacity	15l
Cooling System	Recycle

430 Stainless Steel Tank  
with Hepa Filter

**ID HVC20**   
**VACUUM CLEANER**



Part No.: 26581

Rated Power Input	1200w
Capacity	20l
Cooling System	Recycle

430 Stainless Steel Tank  
with Hepa Filter

**ID HVC30**   
**VACUUM CLEANER**



Part No.: 26582

Rated Power Input	1200w
Belt Speed	30l
Belt Size	Recycle

430 Stainless Steel Tank  
with Hepa Filter

**ID HVC50**   
**VACUUM CLEANER**



Part No.: 26583

Rated Power Input	1200w
Capacity	50l
Cooling System	Recycle

430 Stainless Steel Tank  
with Hepa Filter

► **VACUUM CLEANER / ELECTRIC MIXER**

**ID HVC80**   
**VACUUM CLEANER**



Part No.: 27527

Rated Power Input	3600w
Barrel Size	80L
Plug Type	UK Plug
Cooling System	Recycle
430 Stainless Steel Tank with Hepa Filter	



**ID EM160S**   
**ELECTRIC MIXER**



Part No.: 26021

Rated Power Input	800w
No Load Speed	680r/min
Stirring Paddle Diameter	160mm

(Plate Type Rod)

**ID EM160P**   
**ELECTRIC MIXER**



Part No.: 26020

Rated Power Input	800w
No Load Speed	680r/min
Stirring Paddle Diameter	160mm

(Spiral Type Rod)

► **ELECTRIC MIXER**

**ID EM160HQ**   
**ELECTRIC MIXER**



Part No.: 27822

Rated Power Input	800w
No Load Speed	680r/min
Stirring Paddle Diameter	160mm

(Spiral Type Rod)

**ID GPM800**   
**ELECTRIC MIXER**



Part No.: 26023

Rated Power Input	800w
No Load Speed	550r/min
Stirring Paddle Diameter	160mm

(Plate Type Rod)

**ID MIX164H**   
**ELECTRIC MIXER**



Part No.: 26029

Rated Power Input	900w
No Load Speed	500r/min

**ID MIX165H**   
**ELECTRIC MIXER**



Part No.: 26030

Rated Power Input	1800w
No Load Speed	2000r/min

►► **CORDLESS DRILL**

**ID CL12V**



**CORDLESS DRILL (LI-ION)**



Part No.: 20226

Max. Torque	17Nm
No Load Speed	0-600r/min
Max. Drill Capacity Dia.	0.8-10mm
Rechargeable Battery (Li-ion)	12v
Charge Time	60min
Battery Capacity	1.3Ah

**ID ED-CL12V**



**CORDLESS DRILL (LI-ION)**



Part No.: 26584

Max. Torque	17Nm
No Load Speed	0-600r/min
Max. Drill Capacity Dia.	0.8-10mm
Rechargeable Battery (Li-ion)	12v
Charge Time	60min
Battery Capacity	1.3Ah

**ID CL14.4V**



**CORDLESS DRILL (LI-ION)**



Part No.: 21671

Max. Torque	19Nm
No Load Speed	0-700r/min
Max. Drill Capacity Dia.	0.8-10mm
Rechargeable Battery (Li-ion)	14.4v
Charge Time	60min
Battery Capacity	1.3Ah

**ID ED-CL14.4V**



**CORDLESS DRILL (LI-ION)**



Part No.: 27388

Max. Torque	19Nm
No Load Speed	0-700r/min
Max. Drill Capacity Dia.	0.8-10mm
Rechargeable Battery (Li-ion)	14.4v
Charge Time	60min
Battery Capacity	1.3Ah

**ID ED-CL18V**



**CORDLESS DRILL (LI-ION)**



Part No.: 21672

Max. Torque	19Nm
No Load Speed	0-700r/min
Max. Drill Capacity Dia.	0.8-10mm
Rechargeable Battery (Li-ion)	18v
Charge Time	60min
Battery Capacity	1.5Ah

**ID CL18V**



**CORDLESS DRILL (LI-ION)**



Part No.: 27389

Max. Torque	19Nm
No Load Speed	0-700r/min
Max. Drill Capacity Dia.	0.8-10mm
Rechargeable Battery (Li-ion)	18v
Charge Time	60min
Battery Capacity	1.5Ah

**ID CL36**



**CORDLESS DRILL (LI-ION)**



Part No.: 21667

Max. Torque	5Nm
No Load Speed	0-200r/min
Max. Drill Capacity Dia.	6mm
Rechargeable Battery (Li-ion)	3.6v
Charge Time	180-300min
Battery Capacity	1.3Ah

**ID KCS615**



**CORDLESS DRILL (LI-ION)**



Part No.: 21745

Max. Torque	5Nm
No Load Speed	0-180r/min
Max. Drill Capacity Dia.	6mm
Rechargeable Battery (Li-ion)	3.6v
Charge Time	180-300min
Battery Capacity	1.3Ah

►► **MAGNETIC DRILL**

**ID EMD16**



**MAGNETIC DRILL**



Part No.: 20242

Rated Power Input	900w
No Load Speed	450r/min
Max. Drilling Diameter	16mm
Magnetism	11500w
Connector	MT 2 Shank

**ID EMD30**



**MAGNETIC DRILL**



Part No.: 26354

Rated Power Input	900w
No Load Speed	450r/min
Max. Drilling Diameter	30mm
Magnetism	11500w
Connector	Straight Shank

**ID MD50HQ**



**MAGNETIC DRILL**

**NEW**



Part No.: 26956

Rated Power Input	1600w
No Load Speed	450r/min
Max. Drilling Diameter	50mm
Magnetism	15000w
Connector	MT 2 Shank
Twist Drill Bit	23mm
Core Drill Bit	50mm



►► **BENCH GRINDER**

**ID BG150**   
**BENCH GRINDER**



Part No.: 21652

Rated Power Input	150w
No Load Speed	2950r/min
Max. G.W. Diameter	150mm

**ID BG200**   
**BENCH GRINDER**



Part No.: 21653

Rated Power Input	550w
No Load Speed	2950r/min
Max. G.W. Diameter	200mm

**ID HBG6DC**   
**BENCH GRINDER**



Part No.: 26475

Rated Power Input	250w
No Load Speed	2950r/min
Max. G.W. Diameter	150mm

**ID HBG8DC**   
**BENCH GRINDER**



Part No.: 21736

Rated Power Input	250w
No Load Speed	2950r/min
Max. G.W. Diameter	200mm

**ID HBG10DC**   
**BENCH GRINDER**



Part No.: 26027

Rated Power Input	150w
No Load Speed	2950r/min
Max. G.W. Diameter	150mm

(3 PHASE MOTOR)



►► **SHEAR MACHINE / ELECTRIC NIBBLER**

**ID ESH2.5**   
**SHEAR MACHINE**



Part No.: 26541

Rated Power Input	620w
No Load Strokes	0-1600../min
Max. Cutting Diameter	
Steel	3.2mm
Aluminium	4.0mm

**ID NIB32**   
**ELECTRIC NIBBLER**



Part No.: 20273

Rated Power Input	620w
No Load Strokes	0-1300../min
Max. Cutting Diameter	
Steel	3.2mm
Wood	2.5mm





►► **PRESSURE WASHER**

**ID SR110CL**   
**PRESSURE WASHER**

**NEW**



**CORDLESS PRESSURE WASHER** Part No.: 27833

Rated Power Input	2950w
Max. Working Pressure	110bar
Battery Specification	
Power	24V
Capacity	4000mAH

**ID PW180**   
**PRESSURE WASHER**

**NEW**



Part No.: 27457

Rated Power Input	2200w
Max. Working Pressure	180bar
Flow	390lh

**ID SR185**   
**PRESSURE WASHER**

**NEW**



Part No.: 27933

Rated Power Input	1500w
Max. Working Pressure	185bar
Flow	420lh

**ID SR195**   
**PRESSURE WASHER**

**100% COPPER MOTOR**



Part No.: 21769

Rated Power Input	1500w
Max. Working Pressure	195bar
Flow	390lh

**ID SR210**   
**PRESSURE WASHER**

**100% COPPER MOTOR**



Part No.: 20283

Rated Power Input	2200w
Max. Working Pressure	210bar
Flow	480lh

**ID SR220**   
**PRESSURE WASHER**

**NEW**



Part No.: 27458

Rated Power Input	1200w
Max. Working Pressure	220bar
Flow	330lh

**ID SR230**   
**PRESSURE WASHER**

**NEW**

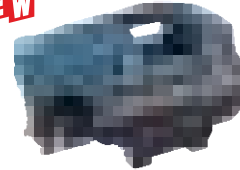

Part No.: 27965

Rated Power Input	1500w
Max. Working Pressure	230Bar
Flow	390lh

**ID SR250**   
**PRESSURE WASHER**

**NEW**

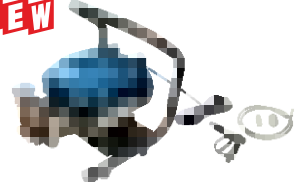

Part No.: 21770

Rated Power Input	2800w
Max. Working Pressure	250bar
Flow	520lh

**ID SR255**   
**PRESSURE WASHER**

**NEW**



Part No.: 26846

Rated Power Input	2200w
Max. Working Pressure	255bar
Flow	720lh

**ID SR280**   
**PRESSURE WASHER**

**NEW**



Part No.: 27966

Rated Power Input	1300w
Max. Working Pressure	280bar
Flow	600lh

**ID SR310**   
**PRESSURE WASHER**

**NEW**



Part No.: 21771

Rated Power Input	3500w
Max. Working Pressure	310bar
Flow	610lh



**IMPACT WRENCH  
DRILL & SCREW DRIVER  
IMPACT SCREW DRIVER**

*Ideally Advanced, Always!*

**▶▶ IMPACT WRENCH**

**ID EW12**   
**IMPACT WRENCH**



Part No.: 26380

Rated Power Input	300w
No Load Speed	1800r/min
Impact	2000im/min
Bolt Size	M8-M12
Square Driver	12.7x12.7mm
Max. Torque	188

**ID EW20**   
**IMPACT WRENCH**



Part No.: 26961

Rated Power Input	340w
No Load Speed	1700r/min
Impact	2000im/min
Bolt Size	M8-M12
Square Driver	12.7x12.7mm
Max. Torque	294

**ID EW22**   
**IMPACT WRENCH**



Part No.: 21713

Rated Power Input	362w
No Load Speed	1700r/min
Impact	1600im/min
Bolt Size	M16-M22
Square Driver	19x19mm
Max. Torque	588



**▶▶ DRILL & SCREW DRIVER**

**ID SD8-10**   
**DRILL & SCREW DRIVER**



Part No.: 21763

Rated Power Input	250w
No Load Speed	0-850r/min
Max. Drilling Diameter	
Steel	10mm
Wood	20mm

**ID EDS10**   
**DRILL & SCREW DRIVER**



Part No.: 21701

Rated Power Input	250w
No Load Speed	0-800r/min
Max. Drilling Diameter	10mm

**ID EDS10N**   
**DRILL & SCREW DRIVER**



Part No.: 20237

Rated Power Input	700w
No Load Speed	0-750r/min
Max. Drilling Diameter	10mm

**ID 101D**   
**DRILL & SCREW DRIVER**



Part No.: 21608

Rated Power Input	230w
No Load Speed	0-3600r/min
Max. Drilling Diameter	6mm

**▶▶ IMPACT SCREW DRIVER**

**ID ISD6**   
**IMPACT SCREW DRIVER**

**NEW**



Part No.: 20259

Rated Power Input	710w
No Load Speed	4300r/min
Self Drilling Screw	6mm
Drywall Screw	5mm



**▶▶ AIR DIE GRINDER / AIR ORBITAL SANDER**

**ID ADG66  
AIR DIE GRINDER**



MINI AIR  
AIR DIE GRINDER

Part No.: 20405

Air Cons.	4CFM@90PSI
No Load Speed	25000r/min
Air Inlet Diameter	1/4Inch

**ID ADG88  
AIR DIE GRINDER**



Part No.: 20406

Air Cons.	7CFM@90PSI
No Load Speed	22000r/min
Air Inlet Diameter	1/4Inch

**ID AOS55  
AIR ORBITAL SANDER**

**NEW**



Part No.: 20407

Air Cons.	3CFM@90PSI
No Load Speed	10500r/min
Air Inlet Diameter	1/4Inch
Pad Size	5"(127mm)

**ID AOS66  
AIR ORBITAL SANDER**

**NEW**



Part No.: 26853

Air Cons.	3CFM@90PSI
No Load Speed	10500r/min
Air Inlet Diameter	1/4Inch
Pad Size	6"(150mm)

**▶▶ AIR IMPACT WRENCH**

**ID AW110  
AIR IMPACT WRENCH**



Part No.: 20409

Air Cons.	4CFM@90PSI
No Load Speed	10000r/min
Air Inlet Dia.	1/4Inch
Max. Torque	75FT/LB (102N/M)
Square Drive Dia.	10mm

**ID AW313  
AIR IMPACT WRENCH**



Part No.: 20412

Air Cons.	5CFM@90PSI
No Load Speed	7000r/min
Air Inlet Dia.	1/4Inch
Max. Torque	230FT/LB (312N/M)
Square Drive Dia.	14mm

**ID AW17K  
AIR IMPACT WRENCH**



AIR  
IMPACT WRENCH KIT

Part No.: 20410

Air Cons.	5CFM@90PSI
No Load Speed	7000r/min
Air Inlet Dia.	1/4Inch
Max. Torque	230FT/LB (312N/M)
Square Drive Dia.	14mm

**ID AW222  
AIR IMPACT WRENCH**



Part No.: 20411

Air Cons.	8CFM@90PSI
No Load Speed	4800r/min
Air Inlet Dia.	1/4Inch
Max. Torque	367FT/LB (500N/M)
Square Drive Dia.	19mm

**▶▶ AIR RATCHET WRENCH / AIR ANGLE GRINDER / AIR DRILL / AIR IMPACT WRENCH**

**ID AR1013  
AIR RATCHET WRENCH**



Part No.: 20408

Air Cons.	5CFM@90PSI
No Load Speed	150r/min
Air Inlet Dia.	1/4Inch
Max. Torque	45FT/LB (61N/M)

**ID AIG100  
AIR ANGLE GRINDER**



**NEW**



Part No.: 26855

Air Cons.	6CFM@90PSI
No Load Speed	10000r/min
Air Inlet Dia.	1/4Inch

**ID AW17K  
AIR IMPACT WRENCH**



**NEW**



Part No.: 26854

Air Cons.	5CFM@90PSI
No Load Speed	1800r/min
Air Inlet Dia.	1/4Inch

**ID AW222  
AIR IMPACT WRENCH**



Part No.: 20413

Air Cons.	15CFM@90PSI
No Load Speed	4200r/min
Air Inlet Dia.	1/2Inch
Max. Torque	1602FT/LB (2180N/M)
Square Drive Dia.	50mm

►► **AIR COMPRESSOR**

**ID AC10**

**AIR COMPRESSOR**

**NEW**



Part No.: 17388

Rated Power Input	1HP
No Load Speed	2800r/min
Air Pressure	125l/min
Working Pressure	8bar
Volume of Gas Tank	10L
Cylinder Diameter	42mm

**ID AC20**

**AIR COMPRESSOR**

**NEW**



Part No.: 20392

Rated Power Input	1HP
No Load Speed	2800r/min
Air Pressure	125l/min
Working Pressure	8bar
Volume of Gas Tank	20L
Cylinder Diameter	42mm

**ID AC30**

**AIR COMPRESSOR**

**NEW**



Part No.: 20393

Rated Power Input	2.5HP
No Load Speed	2800r/min
Air Pressure	147l/min
Working Pressure	8bar
Volume of Gas Tank	30L
Cylinder Diameter	42mm

**ID AC50**

**AIR COMPRESSOR**

**NEW**

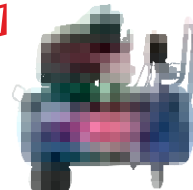

Part No.: 27801

Rated Power Input	3HP
No Load Speed	2800r/min
Air Pressure	185l/min
Working Pressure	8bar
Volume of Gas Tank	50L
Cylinder Diameter	47mm

**ID ACV35**

**AIR COMPRESSOR**

**NEW**



Part No.: 20396

Rated Power Input	1HP
No Load Speed	1380r/min
Air Pressure	135l/min
Working Pressure	8bar
Volume of Gas Tank	35L
Cylinder Diameter	63.7mm x 2

**ID ACV50**

**AIR COMPRESSOR**

**NEW**



Part No.: 20397

Rated Power Input	1HP
No Load Speed	1380r/min
Air Pressure	135l/min
Working Pressure	8bar
Volume of Gas Tank	50L
Cylinder Diameter	63.7mm x 2

**ID ACS30HQ**

**AIR COMPRESSOR**

**NEW**

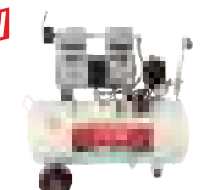

Part No.: 26282

Rated Power Input	1HP
No Load Speed	1380r/min
Air Pressure	135l/min
Working Pressure	8bar
Volume of Gas Tank	30L
Cylinder Diameter	63.7mm x 2

**ID ACS50HQ**

**AIR COMPRESSOR**

**NEW**

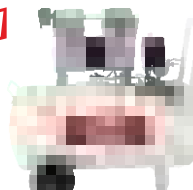

Part No.: 27782

Rated Power Input	1HP
No Load Speed	1380r/min
Air Pressure	135l/min
Working Pressure	8bar
Volume of Gas Tank	50L
Cylinder Diameter	63.7mm x 2

**ID ACS50DM**

**AIR COMPRESSOR**

**NEW**



Part No.: 20395

Rated Power Input	2HP
No Load Speed	1380r/min
Air Pressure	270l/min
Working Pressure	8bar
Volume of Gas Tank	50L
Cylinder Diameter	63.7mm x 4

**ID ACB40-1**

**AIR COMPRESSOR**

**NEW**



Part No.: 27813

Rated Power Input	1HP
No Load Speed	1150r/min
Air Pressure	40l/min
Working Pressure	8bar
Volume of Gas Tank	40L
Cylinder Diameter	51mm x 1

**ID ACB85-1**

**AIR COMPRESSOR**

**NEW**



Part No.: 27812

Rated Power Input	1HP
No Load Speed	1150r/min
Air Pressure	40l/min
Working Pressure	8bar
Volume of Gas Tank	85L
Cylinder Diameter	51mm x 1

**ID ACB100-2**

**AIR COMPRESSOR**

**NEW**



Part No.: 27807

Rated Power Input	2HP
No Load Speed	1020r/min
Air Pressure	170l/min
Working Pressure	8bar
Volume of Gas Tank	100L
Cylinder Diameter	51mm x 1

► **AIR COMPRESSOR**

**ID ACB150-2  
AIR COMPRESSOR**

**NEW**



Part No.: 27806

Rated Power Input	2HP
No Load Speed	1020r/min
Air Pressure	170l/min
Working Pressure	8bar
Volume of Gas Tank	150L
Cylinder Diameter	51mm x 2

**ID ACB150-3  
AIR COMPRESSOR**

**NEW**



Part No.: 27804

Rated Power Input	3HP
No Load Speed	1020r/min
Air Pressure	250l/min
Working Pressure	8bar
Volume of Gas Tank	150L
Cylinder Diameter	65mm x 2

**ID ACB150-5  
AIR COMPRESSOR**

**NEW**



Part No.: 27808

Rated Power Input	5.5HP
No Load Speed	850r/min
Air Pressure	600l/min
Working Pressure	8bar
Volume of Gas Tank	150L
Cylinder Diameter	90mm x 2

**ID ACB200-3  
AIR COMPRESSOR**

**NEW**



Part No.: 27805

Rated Power Input	3HP
No Load Speed	1020r/min
Air Pressure	250l/min
Working Pressure	8bar
Volume of Gas Tank	200L
Cylinder Diameter	65mm x 2

**ID ACB200-5  
AIR COMPRESSOR**

**NEW**



Part No.: 27809

Rated Power Input	5.5HP
No Load Speed	850r/min
Air Pressure	600l/min
Working Pressure	8bar
Volume of Gas Tank	200L
Cylinder Diameter	90mm x 2

**ID ACB200-10  
AIR COMPRESSOR**

**NEW**



Part No.: 27810

Rated Power Input	10HP
No Load Speed	950r/min
Air Pressure	900l/min
Working Pressure	8bar
Volume of Gas Tank	200L
Cylinder Diameter	90mm x 3

**ID ACB300-10  
AIR COMPRESSOR**

**NEW**



Part No.: 27811

Rated Power Input	10HP
No Load Speed	950r/min
Air Pressure	900l/min
Working Pressure	8bar
Volume of Gas Tank	300L
Cylinder Diameter	90mm x 3

**ID ACBH-  
COMPRESSOR HEAD**

**NEW**

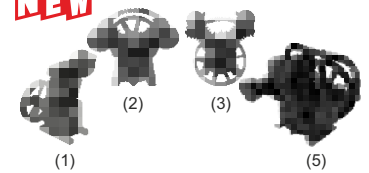

1) ID ACBH-1	27203
2) ID ACBH-2	27204
3) ID ACBH-3	27205
4) ID ACBH-5	27206
5) ID ACBH-10	27803



**DRYWALL SANDER / PEN GUN  
 SPRAY GUN / FOAM SPRAY GUN  
 CEMENT SPRAY GUN / HANDY PAINT ROLLER**

*Ideally Advanced, Always!*

**►► DRYWALL SANDER / PEN GUN**

**ID DWS180**   
**DRYWALL SANDER**

**NEW**



Part No.: 27840

Rated Power Input	950w
No Load Speed	0-2600r/min
Max. Paper Diameter	180mm
Max. Pad Diameter	175mm

**ID DWS225**   
**DRYWALL SANDER**



Part No.: 27915

Rated Power Input	710w
No Load Speed	0-1850r/min
Max. Disc Diameter	225mm



**ID PEN GUN**  
**PEN GUN**



Part No.: 22554

Ideal Pen Gun	
A-130	

**►► SPRAY GUN / FOAM SPRAY GUN**

**ID H827**  
**SPRAY GUN**



Part No.: 23308

H.V.L.P	1-PINT
---------	--------

**ID 990P**  
**SPRAY GUN**



Part No.: 23309

H.V.L.P	1-PINT
---------	--------

**ID IFG1000**  
**FOAM SPRAY GUN**



Part No.: 20351

Working Pressure	0.5-0.8Mpa
Inter Size Dia.	1/4"

**ID IFG1200**  
**FOAM SPRAY GUN**



Part No.: 20352

Working Pressure	0.5-0.8Mpa
Inter Size Dia.	1/4"

**►► FOAM SPRAY GUN / CEMENT SPRAY GUN / HANDY PAINT ROLLER**

**ID IFG500**  
**FOAM SPRAY GUN**

**NEW**



Part No.: 26328

Working Pressure	0.5-0.8Mpa
Inter Size Dia.	1/4"

**ID CG5L**  
**CEMENT SPRAY GUN**

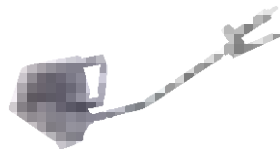

Part No.: 21666

Capacity	5l
Can Be Use With Any Air Compressor	

**ID PR700**  
**HANDY PAINT ROLLER**



Part No.: 22536

Paint Finish Type	All Paint Finishes Rapid Hand Paint Roller
Suitable Surface	Smooth, Semi-Smooth, Semi-Rough, Extra Smooth
Suitable Paint	All Paints



*Ideally Advanced, Always!*

**ELECTRIC SPRAY GUN  
AIRLESS SPRAY UNIT / MANUAL SPRAYER  
BATTERY SPRAYER / GREASE DISPENSER**

**▶▶ ELECTRIC SPRAY GUN**

**ID SG300E**

**ELECTRIC SPRAY GUN**



Part No.: 23310

Rated Power Input	800w
Nozzle Size	0.8mm
Max. Viscosity	140bar
Flow Rate	250ml/min
Container Cap.	800ml

**ID SG400E**

**ELECTRIC SPRAY GUN**



Part No.: 23311

Rated Power Input	400w
Nozzle Size	2.5mm
Max. Viscosity	0.1-0.2bar
Flow Rate	700ml/min
Container Cap.	800ml

**ID SG500E**

**ELECTRIC SPRAY GUN**



Part No.: 23312

Rated Power Input	500w
Nozzle Size	2.5mm
Max. Viscosity	0.1-0.2bar
Flow Rate	800ml/min
Container Cap.	700ml
Hose Length	2m



**▶▶ AIRLESS SPRAY UNIT / MANUAL SPRAYER / BATTERY SPRAYER**

**ID ASG52**

**AIRLESS SPRAY UNIT**

**NEW**



Part No.: 27839

Rated Power Input	1200w
Max. Pressure Flow	1.5l/min
Max. Spraying Pressure	300PSI

**ID ASG53**

**AIRLESS SPRAY UNIT**



Part No.: 23303

Rated Power Input	750w
Max. Pressure Flow	1000ml/min
Max. Spraying Pressure	23mpa
Spray Distance	250-350mm

**ID MS16**

**MANUAL SPRAYER**

**NEW**



Part No.: 26742

Tank Capacity	16l
Pressure	0.3-0.4mpa
Sprayer Type	Backsack
Operated Type	Manual
Material Type	PP,PE
No. of Pcs	1

**ID BS16**

**BATTERY SPRAYER**

**NEW**



Part No.: 26743

Rated Power Output	12v
Output DC	2amp
Battery Capacity	12V8AH
Tank Capacity	16l
Max. Pressure	0.2-0.45mpa
Sprayer Type	BACKSACK
Operated Type	Battery Operated
Material Type	PP,PE

**▶▶ GREASE DISPENSER**

**ID GB5**

**GREASE DISPENSER**

**NEW**



Part No.: 27910

GREASE DISPENSER
5kg - GREASE BUCKET

**ID GB10**

**GREASE DISPENSER**

**NEW**



Part No.: 27911

GREASE DISPENSER
10kg - GREASE BUCKET



► **ARC WELDING MACHINE(ARC / TIG / MIG)**

**ID A220FC**

**ARC WELDING**



Part No.: 23899

KVA	8
O/P Volt	28
O/P Amp	20-200
Duty Cycle	60%
I/P Frequency	50/60hz
Phase	I
Electrode Diameter	3.15-4mm

**ID A250B**

**ARC WELDING**



Part No.: 23900

KVA	9.3
O/P Volt	28
O/P Amp	20-250
Duty Cycle	60%
I/P Frequency	50/60hz
Phase	I
Electrode Diameter	3.15-4mm

**ID A250S2**

**ARC WELDING 1/2 Phase**



Part No.: 23902

KVA	6.8
O/P Volt	28
O/P Amp	20-250
Duty Cycle	60%
I/P Frequency	50/60hz
Phase	I & II
Electrode Diameter	3.15-4mm

**ID A300S2**

**ARC WELDING 1/2 Phase**



Part No.: 26714

KVA	8.6
O/P Volt	32.6
O/P Amp	20-315
Duty Cycle	60%
I/P Frequency	50/60hz
Phase	I & II
Electrode Diameter	3.15-4mm

**ID A250P3**

**ARC WELDING 1/3 Phase**



Part No.: 23901

KVA	8.3
O/P Volt	26.5
O/P Amp	20-250
Duty Cycle	85%
I/P Frequency	50/60hz
Phase	III
Electrode Diameter	4mm

**ID A400S3**

**ARC WELDING 1/3 Phase**



Part No.: 27228

KVA	18
O/P Volt	36
O/P Amp	20-400
Duty Cycle	60%
I/P Frequency	50/60hz
Phase	I & III
Electrode Diameter	4&5mm

**ID TA300S3**

**ARC WELDING ARC+TIG**



Part No.: 23910

KVA	8.3
O/P Volt	23
O/P Amp	10-315
Duty Cycle	60%
I/P Frequency	50/60hz
Phase	I & III
Electrode Diameter	3.15-4mm

**ID TA400S3**

**ARC WELDING ARC+TIG**



Part No.: 23911

KVA	13
O/P Volt	26
O/P Amp	20-400
Duty Cycle	60%
I/P Frequency	50/60hz
Phase	I & III
Electrode Diameter	4mm

**ID IMT200**

**ARC WELDING ARC+TIG**



Part No.: 23913

KVA	8.4
O/P Volt	18
O/P Amp	10-200
Duty Cycle	60%
I/P Frequency	50/60hz
Phase	I
Electrode Diameter	3.15-4mm

**ID A400/255MIG**

**ARC WELDING MIG**



Part No.: 23906/23903

KVA	37.5
O/P Volt	16.5-50
O/P Amp	80-500
Duty Cycle	85%
I/P Frequency	50/60hz
Phase	III

**ID AIP10**

**ARC WELDING**



Part No.: 23865

KVA	7
O/P Volt	28
O/P Amp	20-200
Duty Cycle	60%
I/P Frequency	50/60hz
Phase	I
Electrode Diameter	2.5-3.15mm

**ID ARC300**

**ARC WELDING**



Part No.: 26752

KVA	7
O/P Volt	28
O/P Amp	20-300
Duty Cycle	60%
I/P Frequency	50/60hz
Phase	I
Electrode Diameter	2.5-3.15mm



►► **IGBT WELDING**

**ID ARC255DV**

**IGBT WELDING**

**NEW**



Part No.: 27889

Rated Voltage	220	380
KVA	6.8	5.8
O/P Volt	28	28
O/P Amp	20-255	20-255
Duty Cycle	40%	60%
I/P Frequency	50/60hz	50/60hz
Electrode Dia.	2.5-3.15mm	2.5-3.15mm

**ID G220A**

**IGBT WELDING**



Part No.: 26044

KVA	7
O/P Volt	28
O/P Amp	20-220
Duty Cycle	60%
I/P Frequency	50/60hz
Phase	I
Electrode Diameter	2.5-3.15mm

**ID G230A**

**IGBT WELDING**

**NEW**



Part No.: 27207

KVA	6.3
O/P Volt	29
O/P Amp	20-140
Duty Cycle	60%
I/P Frequency	50/60hz
Phase	I
Electrode Diameter	2.5-3.15mm

**ID G250A-II**

**IGBT WELDING**

**NEW**



Part No.: 27229

KVA	6.8
O/P Volt	29
O/P Amp	20-250
Duty Cycle	60%
I/P Frequency	50/60hz
Phase	I & II
Electrode Diameter	2.5-3.15mm

►► **IGBT WELDING / TRANSFORMER WELDING MACHINE**

**ID G300A-II**

**IGBT WELDING**

**NEW**



Part No.: 27230

KVA	7.9
O/P Volt	32
O/P Amp	20-315
Duty Cycle	60%
I/P Frequency	50/60hz
Phase	I & II
Electrode Diameter	2.5-3.15mm

**ID SUPER30**

**IGBT WELDING**



Part No.: 23866

KVA	7
O/P Volt	28
O/P Amp	20-200
Duty Cycle	60%
I/P Frequency	50/60hz
Phase	I
Electrode Diameter	2.5-3.15mm

**ID E200A**

**TRANSFORMER WELDING**



TRANSFORMER WELDING MACHINE Part No.: 23873

KVA	8
O/P Volt	88
O/P Amp	200
Duty Cycle	60%
I/P Frequency	50/60hz
Phase	I
Electrode Diameter	2.5-3.15mm

**ID E250A**

**TRANSFORMER WELDING**



TRANSFORMER WELDING MACHINE Part No.: 23874

KVA	10
O/P Volt	44
O/P Amp	200
Duty Cycle	60%
I/P Frequency	50/60hz
Phase	I
Electrode Diameter	2.5-3.15mm

**ID 92**

**TRANSFORMER WELDING**



TRANSFORMER WELDING MACHINE Part No.: 23870

KVA	10
O/P Volt	50
O/P Amp	250
Duty Cycle	60%
I/P Frequency	50/60hz
Phase	I+II
Electrode Diameter	2-3.15mm

**ID 10+2**

**TRANSFORMER WELDING**



TRANSFORMER WELDING MACHINE Part No.: 23868

KVA	10
O/P Volt	45
O/P Amp	250
Duty Cycle	60%
I/P Frequency	50/60hz
Phase	I+II
Electrode Diameter	2-3.15mm



**» WELDING TORCH / CUTTING TORCH**

**ID CT11**

**WELDING TORCH**



Part No.: 21485

This Torch used for Cutting Material by the Gas.

**ID CT12**

**WELDING TORCH**



Part No.: 21486

This Torch used for Cutting Material by the Gas.

**ID CT22**

**CUTTING TORCH**



Part No.: 21156

This Torch used for Cutting Material by the Gas.

**ID CT33**

**CUTTING TORCH**



Part No.: 21157

This Torch used for Cutting Material by the Gas.

**» CUTTING NOZZLES / REGULATOR**

**CUTTING NOZZLES**

**CUTTING NOZZLES**



Part No.: 21150-21155

A1/16	21150
A1/32	21151
A3/64	21152
B1/16	21153
B1/32	21154
B3/64	21155

**ID ArR252B**

**REGULATOR**

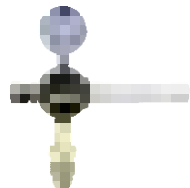

Part No.: 21463

Gas Type Argon

**ID OR64G/B**

**REGULATOR**

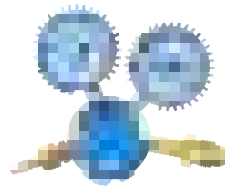

Part No.: 21464

Gas Type Oxygen

**ID OR74C/TR64B**

**REGULATOR**

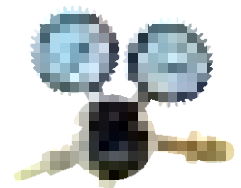

Part No.: 21465

Gas Type Co<sub>2</sub>

**ID OR84A/ArR64B**

**REGULATOR**



Part No.: 21466

Gas Type Argon



►► **CHAIN BLOCK**

**ID CHAIN BLOCK  
CHAIN BLOCK**

- 1) Professional Quality
- 2) G-80 Hardened Alloy Load Chain
- 3) Tried & Tested To Lift 1.5% Additional



WITH LOAD CHAIN					WITHOUT LOAD CHAIN
SIZE	LOAD CHAIN	LIFT			SIZE
1 TON	6mm	3mtr	6mtr	10mtr	1 TON
2 TON	8mm	3mtr	6mtr	10mtr	2 TON
3 TON	8mm	3mtr	6mtr	10mtr	3 TON
5 TON	10mm	3mtr	6mtr	10mtr	5 TON

►► **WIRE ROPE HOIST**



**ID ROPE HOIST  
ELECTRIC WIRE ROPE HOIST**

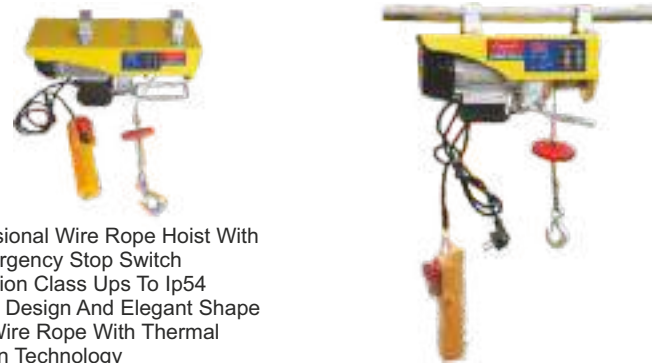

- 1) Professional Wire Rope Hoist With New Emergency Stop Switch
- 2) Protection Class Ups To Ip54
- 3) Unique Design And Elegant Shape
- 4) Steel Wire Rope With Thermal Prevention Technology

MODEL	METHOD OF USE	RATED LIFTING	
		WEIGHT (Kg)	LIFTING HEIGHT (m)
ID PA500 X 12m	SINGLE HOOK	250	12
	DOUBLE HOOK	500	6
ID PA500 X 20m	SINGLE HOOK	250	20
	DOUBLE HOOK	500	10
ID PA1000 X 12m	SINGLE HOOK	500	12
	DOUBLE HOOK	1000	6
ID PA1000 X 20m	SINGLE HOOK	500	20
	DOUBLE HOOK	1000	10
ID PA1200 X 12m	SINGLE HOOK	600	12
	DOUBLE HOOK	1200	6
ID PA1200 X 20m	SINGLE HOOK	600	20
	DOUBLE HOOK	1200	10

► **DIAMOND BLADE**

**HUI-FENG  
DIAMOND BLADE**

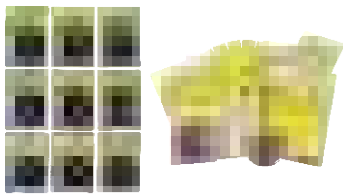

Diamond Blades  
&  
Cup Wheel (Hot Press).

**ID "PRO."  
DIAMOND BLADE**



Diamond Blades,  
Cup Wheel  
&  
Tuck Point.  
(Sizes-2"-32")

**ID "PRO. TEZ"  
DIAMOND BLADE**



Diamond Blades  
(Semi Hot Press).  
  
(Size-4")

**ID "IGS SERIES"  
DIAMOND BLADE**



IDEAL "IGS SERIES"  
Granite Special Diamond Blade.  
  
Diamond Blades,  
Flat Turbo(Hot Press)  
(Size-4"-14")

**ID "Z-SERIES"  
DIAMOND BLADE**

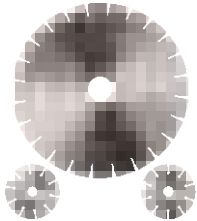

IDEAL "IGS SERIES"  
Granite Special Diamond Blade.  
  
Diamond Blades,  
(Hot Press)  
(Size-4"-14")

**ID "NF438-SERIES"  
DIAMOND BLADE**



Segment, Rim, Turbo  
  
Size: 4"

**ID "X-SERIES"  
DIAMOND BLADE**

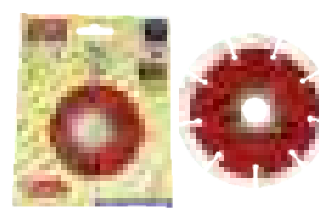

Segment, Rim, Turbo  
  
Size: 4"-5"

**ID "IDSS-SERIES"  
DIAMOND BLADE**



Segment, Rim, Turbo  
  
Size: 4"-5"

► **GLASS WHEEL**

**ID  
GLASS WHEEL**



Segment, Rim, Turbo Type.  
Vacuum Brazed Wheel.



►► **TCT BLADE**

**ID "THIN KERF"  
TCT BLADE**

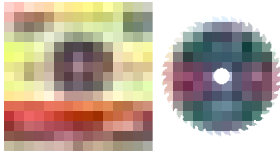

IDEAL "THIN KERF(1.6mm)" TCT Blade

For Wood:  
4"(110mm)-12"(300mm)

**ID "GOLD"  
TCT BLADE**

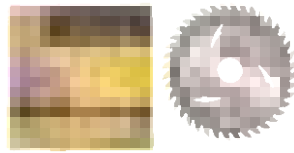

"GOLD SERIES" TCT Blade.

For Wood:  
4"(110mm)-14"(355mm)  
For Aluminium:  
10"(250mm)-14"(355mm)

**ID "IGS SERIES"  
TCT BLADE**



IDEAL "IGS" TCT Blade.

For Wood:  
4"(110mm)-14"(355mm)  
For Aluminium:  
10"(250mm)-14"(355mm)

**HUI-FENG  
TCT BLADE**

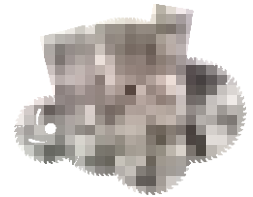

"HUI FENG" TCT Blade.

For Wood:  
4"(110mm)-14"(355mm)  
For Aluminium: 4"(110mm)  
10"(250mm)-14"(355mm)

►► **CUT-OFF WHEEL / CUTTING WHEEL**

**ID "GREEN-SERIES"  
CUT-OFF WHEEL**



GREEN SERIES

4"(107mm), 4-1/2"(115mm),  
5"(125mm), 7"(180mm),  
9"(230mm), 12"(305mm),  
14"(355mm)  
1Net

**ID "RED-SERIES"  
CUT-OFF WHEEL**



RED SERIES

4"(107mm), 14"(355mm)  
2Net

**ID "IGC-SERIES"  
CUTTING WHEEL**



"IGC SERIES" "GREEN"  
Cutting Wheels

4"(100mm) & 14"(355mm)  
2Net

**ID "IGC-SERIES"  
CUTTING WHEEL**



"IGC SERIES" "BLACK"  
Cutting Wheels

4"(100mm)  
2Net

►► **CUTTING WHEEL**

**ID "IGC-SERIES"  
CUTTING WHEEL**



"IGC SERIES" "RED"  
Cutting Wheel

4"(100mm)



**►► D.C./ G.C./ W.A. WHEELS / FLAP DISC**

**ID**  
**D.C. WHEEL**



"GREEN SERIES"  
 D.C. WHEEL.

4"(100mm), 4-1/2"(115mm), 5"(125mm),  
 7"(180mm), 9"(230mm)

**ID**  
**G.C. WHEEL**



G.C. WHEEL.

Stone Polishing

**ID**  
**W.A. WHEEL**



IDEAL FLEXIBLE  
 GRINDING WHEELS

WA#36, #46, #60, #80

**ID**  
**FLAP DISC**



SUPER INOX "METAL HEAD"  
 4"(100mm), 5"(125mm),  
 7"(180mm)

**►► FIBER, VELCRO DISC / POLISHING WHEEL / WATER PAPER**

**ID**  
**FIBER, VELCRO DISC**



FIBER & VELCRO DISC

4"(100mm), 5"(125mm),  
 7"(180mm)

**ID**  
**POLISHING WHEEL**



Non-Woven, FELT & STONE  
 POLISHING WHEEL

For Steel & Stone Polishing

**ID**  
**WATER PAPER WET & DRY**



Available GRIT#  
 80#, 120#, 150#, 180#, 220#,  
 320#, 400#, 600#, 800#, 1000#  
 2000#, 3000#



**►► CUT-OFF WHEEL / D.C. / G.C. WHEEL**

**HUI-FENG**  
**CUT-OFF WHEEL**



HUI-FENG  
 CUT-OFF WHEELS(2NET)

4"(105mm), 5"(125mm), 7"(180mm),  
 9"(230mm), 12"(305mm)  
 14"(355mm)

**HUI-FENG**  
**D.C. WHEEL**



HUI-FENG D.C. WHEELS

4"(100mm), 5"(125mm),  
 7"(180mm)

**HUI-FENG**  
**G.C. WHEEL**



HUI-FENG G.C. WHEELS

For Stone Polishing



► **ARMATURES**



**GDC34**



**GSB13RE**



**GWS6-100**



**GWS7-100**



**GWS20-180**

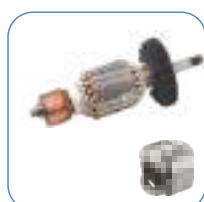

**GWS20-230**



**GBH2-20**



**GBH2-22**

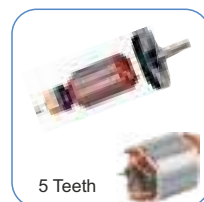

**GBH2-24**



**GBH2-26**



**GBH-11E**



**GST85PB**



**CM4SA**



**CM4SB**



**CC14SF**



**DU10**



**C7**



**C7SC**



**G10SS**



**PDA100M**



**PDA100D**



**G15SA2**



**G18SE2**



**PR-38E**



**PH65A**



**F-20A**



**1285**



**4107B**

**» ARMATURES**



**MT-410**



**2414B**



**MT-240**



**5806B**



**5900B**



**TCH-355B**



**HM0810**



**906**



**3612BR**



**1900B**

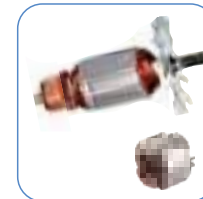

**5016B**

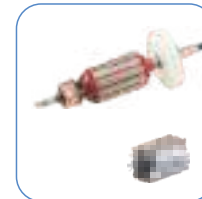

**DW801**



**DW871**



**DW28410**



**BDP80-20**



**3401**



**5791**

**» SWITCHES(HIGH QUALITY)**



**ID MT410**



**ID EG10**



**ID GSB-13RE**



**ID GSH388**



**ID CC14SF**



**ID CC14STD**



**ID CM4SA**



**ID DW831**



**ID DW801**



**ID DW801**



**ID G155A2**

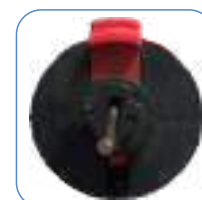

**ID GBH2-26**



► **SWITCHES(HIGH QUALITY)**



ID GBH2—26



ID GBH2—26



ID GCO200



ID GCO2000



ID GWS-20-180



ID 13RF



ID AIP10



ID CC200



ID CC90/130



ID CO355DC



ID DH26DC



ID DH26DC



ID DL810T



ID DW871



ID ED10A



ID ED-6RF



ID EDS10



ID FS210AC



ID GSB570VR



ID GSH11E



ID GSH11E



ID GWS6100  
Black & Brown



ID MS255PF



ID PH65M



ID SP180C



ID SP180DC



ID SP7G



ID SP7G



ID WCS185



ID WR12E



ID MT410



ID CM4DC



ID HR2450



ID HR2470



ID CM4SA(L)



PAINT MIXER

# SPARE PARTS

(CARBON BRUSHES / A.B. WASHER / GEAR & PINION /  
 FRAME/COVER / SPINDLES / CHUCKS / HOLESAW/ADAPTORS /  
 SDS + BITS / CHISELS / CORE BITS)

*Ideally Advanced, Always!*

## ►► CARBON BRUSHES / A.B. WASHER / GEAR & PINION / FRAME/COVER

### IDEAL & HUI-FENG

#### CARBON BRUSHES



Ideal & Hui Feng Carbon Brushes  
 All Types of Carbon Brushes For  
 Multiple Types of Machines.

### ID

#### A.B. WASHER

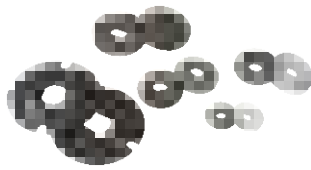

All Types of A.B. Washers.

### ID

#### GEAR & PINION



All Types of Gear & Pinions For  
 Multiple Types of Machines.

### ID

#### FRAME/COVER



Multi Types of Frame/Cover For  
 Multi Types Gears/Machines.

## ►► SPINDLES / CHUCKS / HOLESAW/ADAPTORS / SDS + BITS

### ID

#### SPINDLES

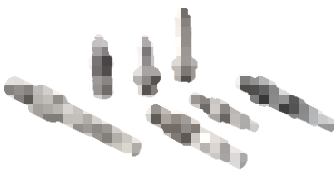

Multi Types of Spindles.

### ID

#### CHUCKS



1. Drill Chucks
2. Taper Chucks
3. Key-Less Chucks
4. Chuck Keys

### ID SDS

#### HOLESAW/ADAPTORS



CONCRETE SDS  
 HOLESAW & ADAPTORS

### ID

#### SDS + BITS



SDS + BITS  
 4mm-30mm  
 (110mm-600mm LONG)

## ►► CHISELS / CORE BITS

### ID

#### CHISELS



CHISELS  
 (SDS PLUS, HEX, MAX & PH65)

### ID

#### CORE BITS



Multiple Types of Corbits For  
 Stone & Concrete.



*Ideally Advanced, Always!*

(BROACH CUTTER / CARBIDE HOLESAW / HOLESAW SETS / STEP DRILL BITS / WIRE BRUSHES / BEARING PULLERS / PAINT MIXER ROD / BUFFING PADS / BREAKER GREASE)

**►► BROACH CUTTER / CARBIDE HOLESAW / HOLESAW SETS / STEP DRILL BITS**

**ID  
BROACH CUTTER**



Broach Cutter  
Available in Multi size.

**ID  
CARBIDE HOLESAW**



TCT Carbide Holesaw  
Available in multiple Sizes.

**ID  
HOLESAW SETS**



Holesaw Sets

- 20690 - 12pcs - Bimetal Holesaw Set
- 23204 - 16pcs - Wood Holesaw Set
- 20209 - 6pcs - Wood Holesaw Set

**ID  
STEP DRILL BITS**

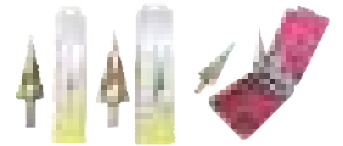

Step Drill Bit / Bits Set

- 21098 - 12mm - Step Drill Bit
- 20698 - 20mm - Step Drill Bit
- 20699 - 32mm - Step Drill Bit
- 20700 - 3pcs(12,20,32mm) - Step Drill Bit

**►► WIRE BRUSHES / BEARING PULLER / PAINT MIXER ROD / BUFFING PADS**

**ID  
WIRE BRUSHES**



1. Cup Wire Brush
2. Circular Type
3. Rod Type (Circular/Straight)
4. Wire Brush Set (5 Pcs)

**ID AB-1/AB-2/AB-3  
BEARING PULLER**



Part No.: Model No.: Size:

20093	AB - 1	25mm
21100	AB - 2	50mm
20457	AB - 3	75mm

**ID  
PAINT MIXER ROD**



Part No.:	Model No.:	
22528	IMR400H	☐
22532	IMR600H	☐
22529	IMR400S	☐
22533	IMR600H	☒
22530	IMR45Z	☐
22531	IMR55C	☐
22534	IMR612	☐

**ID  
BUFFING PADS**

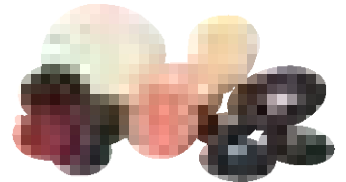

1. Rubber Backing Pads
2. Velcro Backing Pads
3. Sponges Pads
4. Wool Bonnets

**►► BREAKER GREASE**

**ID BKG100  
BREAKER GREASE**



Part No.: 26358

High Density Breaker Grease  
for Multi Uses.

ID BKG100 in 100g.

**ID BKG500  
BREAKER GREASE**

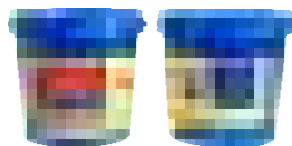

Part No.: 20014

High Density Breaker Grease  
for Multi Uses.

ID BKG500 in 500g.



► **ROUTER BITS**

**ID**  
**CORNER BITS**

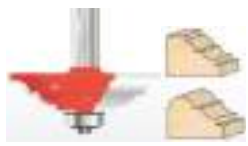

BEARING SIZE :  
D-13 x B-5 x Thick-4

Model	Wood Size (mm)	Dia (mm)	Shank (mm)
ID135	15x10	38	8
ID140	22x10	50	8
ID141	22x12	50	8
ID145	25x15	55	8
ID152	35x15	72	8

**ID**  
**REBBETING BITS**

FOUR SIDE  
REBBETING BITS



Model	Thick (mm)	Depth (mm)	Shank (mm)
ID126	6	12	8
ID128	10	12	8
ID1210	35	12	8

**ID**  
**SLOTING CUTTER**

V-TYPE  
SLOTING CUTTER

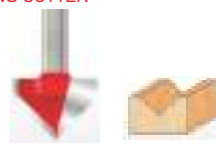

Model	D	H	Shank (mm)
ID934	12.7	12.7	8

**ID**  
**FLUSH TRIM BITS**

FLUSH TRIM  
BITS WITH BEARING



BEARING SIZE :  
D-13 x B-5 x Thick-4

Model	Dia (mm)	Cutting Length (mm)	Shank (mm)
ID5001	4	8	8
ID5002	6	15	8
ID5003	8	20	8
ID5004	10	20	8

**ID**  
**FLUSH TRIM BITS**

FLUSH TRIM BITS  
WITH BEARING LONG (50mm)



BEARING SIZE :  
D-13 x B-5 x Thick-4

Model	Dia (mm)	Cutting Length (mm)	Shank (mm)
ID5002	6	15	8
ID5003	8	20	8
ID5004	10	20	8

**ID**  
**OVOLO BITS**

OVOLO BITS  
(BEADING BITS)



BEARING SIZE :  
D-13 x B-5 x Thick-4

Model	Dia (mm)	Cutting Length (mm)	Radius
ID9031	21	10	4
ID9032	25	12	6
ID9033	29	14	8
ID9034	33	16	10
ID9035	37	18	12
ID9036	43	21	15
ID9037	53	26	20
ID9038	63	31	25

**ID**  
**COVE BEAD BITS**



BEARING SIZE :  
D-13 x B-5 x Thick-4

Model	Dia (mm)	Cutting Length (mm)	Radius
ID9041	25	8	4
ID9042	29	10	6
ID9043	33	12	8
ID9044	37	14	10
ID9045	43	16	12
ID9046	53	20	15
ID9047	63	25	20
ID9048	73	30	25

**ID**  
**COVE BEAD BITS**



BEARING SIZE :  
D-13 x B-5 x Thick-4

Model	Dia (mm)	Cutting Length (mm)	Radius
ID9051	29	14	3
ID9052	37	18	5
ID9053	33	10	4
ID9054	38	12	6

**ID**  
**COVE-OVOLO PROFILE**

COVE-OVOLO  
PROFILE BITS



Model	Dia (mm)	Cutting Length (mm)	Cutting Area (mm)
ID9061	29	14	10x10
ID9062	37	18	15x15
ID9063	33	10	10x8
ID9064	38	12	15x12

**ID**  
**OGEE FILLET BITS**

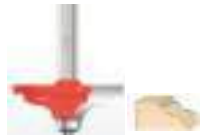

Model	Dia (mm)	Cutting Length (mm)	Cutting Area (mm)
ID9071	29	14	10x10
ID9072	37	18	15x15
ID9073	33	10	10x8

**ID**  
**ROMAN OGEE BITS**



Model	Dia (mm)	Cutting Length (mm)	Cutting Area (mm)
ID9081	29	14	10x10
ID9082	37	18	15x15
ID9083	33	10	10x8
ID9084	38	12	15x12

**ID**  
**REBBETING**

REBBETING  
(SLOT BITS)



Model	Dia (mm)	Cutting Length (mm)	Cutting Area (mm)
ID9091	35	4	4x12
ID9092	35	6	6x12
ID9093	35	8	8x12
ID9094	35	9	9x12
ID9095	35	10	10x12
ID9096	35	12	12x12
ID9097	35	15	15x12
ID9098	35	20	20x12
ID9099	35	25	25x12
ID9100	35	32	32x12
ID9200	35	38	38x12

► **ROUTER BITS**

**ID**

**CORE BOX ROUND**

CORE BOX ROUND BITS



Model	Dia (mm)	Cutting Length (mm)	Cutting Area (mm)
ID9101	6	8	6x5
ID9102	8	9	8x6
ID9103	10	10	10x7
ID9104	12	11	12x8
ID9105	14	12	14x9
ID9106	16	13	16x10
ID9107	18	14	18x12
ID9108	20	15	20x14

**ID**

**STEP & ROUND BITS**

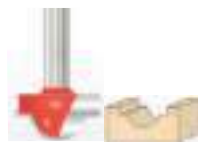

Model	Dia (mm)	Cutting Length (mm)	Cutting Area (mm)
ID9201	10	8	10x5
ID9202	12	9	12x6
ID9204	14	10	14x7
ID9205	16	11	16x8
ID9206	20	13	20x10
ID9207	22	14	22x12
ID9208	24	15	24x14

**ID**

**STEP BITS**



Model	Dia (mm)	Cutting Length (mm)	Cutting Area (mm)
ID9301	21	8	10x10
ID9302	25	12	15x15
ID9303	29	8	10x8
ID9304	33	12	15x12

**ID**

**CHAMFER BIT**



Model	Dia (mm)	Cutting Length (mm)	Cutting Area (mm)
ID9401	29	10	10x10
ID9402	37	16	15x15
ID9403	33	10	10x8
ID9404	38	12	15x12
ID9405	40	14	12x10
ID9406	48	18	15x12

**ID**

**STRAIGHT BITS(20mm)**



BEARING SIZE : D-13 x B-5 x Thick-4

Model	Dia (mm)	Cutting Length (mm)	Cutting Area (mm)
ID9501	4	8	8x4
ID9502	6	15	15x6
ID9503	8	20	20x8
ID9504	10	20	20x10
ID9505	12	20	20x12
ID9506	12.7	20	20x12.7
ID9507	15	20	20x15
ID9508	19	20	20x19
ID9509	20	20	20x20
ID9510	25	20	20x25

**ID**

**STRAIGHT BITS(38mm)**



BEARING SIZE : D-13 x B-5 x Thick-4

Model	Dia (mm)	Cutting Length (mm)	Cutting Area (mm)
ID9503	8	38	38x8
ID9504	10	38	38x10
ID9505	12.7	38	38x12.7

**ID**

**STRAIGHT BITS(50mm)**

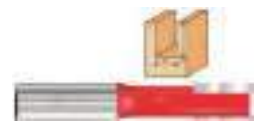

BEARING SIZE : D-13 x B-5 x Thick-4

Model	Dia (mm)	Cutting Length (mm)	Cutting Area (mm)
ID9503	8	50	50x8
ID9504	10	50	50x10
ID9505	12.7	50	50x12.7

**ID**

**STRAIGHT BITS(75mm)**



BEARING SIZE : D-13 x B-5 x Thick-4

Model	Dia (mm)	Cutting Length (mm)	Cutting Area (mm)
ID9503	8	75	75x8
ID9504	10	75	75x10
ID9505	12.7	75	75x12.7

**ID**

**CLASSICAL PLUNGE**

CLASSICAL PLUNGE CUT BEADING BITS



Model	Dia (mm)	Cutting Length (mm)	Cutting Area (mm)
ID9601	16	11	16x8
ID9602	20	13	20x10
ID9603	24	15	24x12
ID9604	28	18	28x14

**ID**

**PLUNGE CUT BITS**

PLUNGE CUT BEADING BITS



BEARING SIZE : D-13 x B-5 x Thick-4

Model	Dia (mm)	Cutting Length (mm)	Cutting Area (mm)
ID9701	6	7	6x7
ID9702	8	8	8x5
ID9703	10	10	10x6
ID9704	12	11	12x7

**ID**

**DOUBLE FILLET BITS**

DOUBLE FILLET COVE BITS



Model	D	H	Cutting Area (mm)
ID9801	29	14	10x10
ID9802	37	18	15x15
ID9803	33	10	10x8
ID9804	38	12	15x12

**ID**

**BOTTOM OLOGO BITS**



Model	D	H	Cutting Area (mm)
ID9901	29	14	10x10
ID9902	37	18	15x15
ID9903	33	10	10x8
ID9904	38	12	15x12

► **ROUTER BITS**

**ID**

**TOP OLOGO BITS**



Model	D	H	Cutting Area (mm)
ID9911	29	14	10x10
ID9912	37	18	15x15
ID9913	33	10	10x8
ID9914	38	12	15x12

**ID**

**DOUBLE OLOGO BITS**

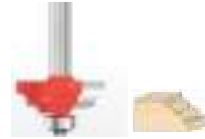

⊙ BEARING SIZE :  
D-13 x B-5 x Thick-4

Model	D	H	Cutting Area (mm)
ID9921	29	14	10x10
ID9922	37	18	15x15
ID9923	33	10	10x8
ID9924	27	12	15x12

**ID**

**CENTER OLOGO BITS**

CENTER OLOGO BITS  
(THREAD BITS)



Model	Dia (mm)	Cutting Length (mm)	Cutting Area (mm)
ID9933	10	7	10x7
ID9934	12	8	12x8
ID9935	14	9	14x9
ID9936	16	10	16x10
ID9937	18	11	18x11
ID9938	20	12	20x12
ID9939	24	13	24x13
ID9940	30	14	30x14

**ID**

**CENTER(CARVING BITS)**



Model	Dia (mm)	Cutting Length (mm)	Cutting Area (mm)
ID9943	10	7	10x7
ID9944	12	8	12x8
ID9945	14	9	14x9
ID9946	16	10	16x10
ID9947	18	11	18x11
ID9948	20	12	20x12
ID9949	24	13	24x13
ID9950	30	14	30x14

**ID**

**CLASSIC ROMAN OGEE**

CLASSIC ROMAN OGEE  
(CEBTER BITS)



⊙ BEARING SIZE :  
D-13 x B-5 x Thick-4

Model	Dia (mm)	Cutting Length (mm)	Cutting Area (mm)
ID9951	29	14	20x10
ID9952	37	18	16x16
ID9953	33	10	28x10
ID9954	38	12	32x10

**ID**

**OVOLO BITS**

THUMB  
MOULD BITS)



⊙ BEARING SIZE :  
D-13 x B-5 x Thick-4

Model	Dia (mm)	Cutting Length (mm)	Cutting Area (mm)
ID9961	29	14	10x10
ID9962	37	18	15x15
ID9963	33	10	10x8
ID9964	38	12	15x12

**ID**

**CORNER ROUND BITS**



⊙ BEARING SIZE :  
D-13 x B-5 x Thick-4

Model	Dia (mm)	B	Shank (mm)
IDTS-1	14	2.5	6
IDTS-2	15.5	3	6
IDTS-3	26	6.5	6

**ID**

**TRIM BITS**



⊙ BEARING SIZE :  
D-13 x B-5 x Thick-4

Model	Dia (mm)	H	Shank (mm)
IDTS-4	7	20	6
IDTS-5	9.5	25	6
IDTS-6	13	25	6

**ID**

**STRAIGHT BITS**



Model	Dia (mm)	Cutting Length (mm)	Shank (mm)
IDTS-10	6	20	6
IDTS-10AY	4	13	6.35
IDTS-11	8	20	6
IDTS-11A	10	20	6
IDTS-11AY	8	20	6.35
IDTS-11Y	10	20	6.35
IDTS-12	12	20	6

**ID**

**TRIMMER TOP BERING**

TRIMMER TOP  
BERING BITS

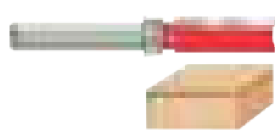

Model	Dia (mm)	B	Shank (mm)
IDTS-15	12.7	25.4	6
IDTS-15Y	12.7	25.4	6

**ID**

**V-GROOVE BITS**



Model	Dia (mm)	H	Shank (mm)
IDTS-24Y	8	8	6.35
IDTS-25Y	10	10	6.35
IDTS-26Y	12	12	6.35

**ID**

**BEADING BITS**



Model	Dia (mm)	H	Shank (mm)
IDTS-41Y	35	6	6.35
IDTS-42Y	35	8	6.35
IDTS-43Y	35	10	6.35
IDTS-44Y	35	12	6.35

**▶▶ HINGE BORING BIT / ROUTER BITS SET**

**ID HINGE BIT  
HINGE BORING BIT**



Part No.: 21043

Ideal Hinge Boring Bit  
Size:

35mm

**ID PRO12  
ROUTER BITS SET**

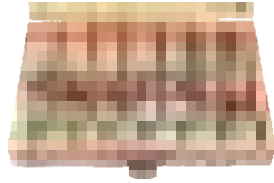

Part No.: 21278

ID PRO12

12PCS of BITS.

**ID PLUS12  
ROUTER BITS SET**



Part No.: 21183

ID PLUS12

12PCS of BITS.

**ID PRO35  
ROUTER BITS SET**

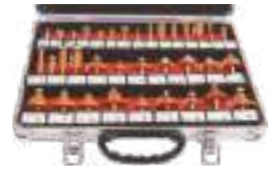

Part No.: 21279

ID PRO35

35PCS of BITS.

**▶▶ ROUTER BITS SET / COUNTER PROFILE BITS SET / TRIMMER BIT SET**

**ID PRO87  
ROUTER BITS SET**

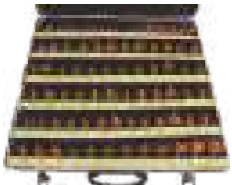

Part No.: 21280

ID PRO87

87PCS of BITS.

**ID RB3S  
COUNTER PROFILE BIT**



COUNTER PROFILE  
ROUTER BITS SET

ID RS3S

3PCS of BITS.

8mm(26116) & 12mm(25999)

**ID TRIMMER BIT SET  
ROUTER BITS SET**



TRIMMER BITS SET

Part No.: 21281

ID TRIMMER BIT SET

6PCS of BITS.



**▶▶ WOOD AUGER BITS / AUGER DRILL BITS**

**ID WAB...  
WOOD AUGER BIT**



ID WOOD AUGER BITS

Size:

12mm(26075)  
16mm(26076)  
19mm(26077)  
25mm(26078)

**ID ADB...  
AUGER DRILL BIT**



EARTH  
AUGER DRILL BITS

ID AUGER DRILL BITS

Size:

100mm(20453), 120mm(26818)  
150mm(20454), 200mm(20455)  
250mm(26819), 300mm(26820)



► **GROOVE CUTTER / PLANER BLADES/KNIFE**

**ID**  
**GROOVE CUTTER**



Grooving Cutter  
(“V” Type And FIL FIL Type)

3" & 4" (4mm-12mm)

**ID**  
**TCT PLANER BLADE**

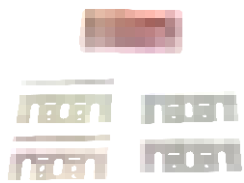

TCT PLANER BLADE

F20A, 1900B, BOSCH B&D

**ID**  
**HAND PLANER BLADE**



TCT Hand Planer Blade  
(Hole & Without Hole)

1" ,1-1/4", 1-1/2", 1-3/4",2" and 2-1/2"

**ID**  
**TCT PLANER KNIFE**

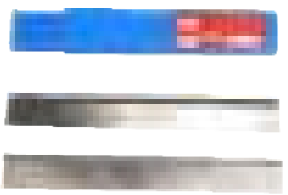

TCT PLANNER KNIFE

(9"-24")

► **PLANER BLADE**

**ID**  
**PLANER BLADE**



HSS Planer Blade  
(82mm)

F20A, 1900B, BOSCH B&D



► **EXTENSION PIPE / WEBBING SLING / PALLET TRUCK**

**ID PE25 / PE50**  
**EXTENSION PIPE**



Part No.: 26388-89

Extension Pipe  
For Pressure Washer

26388 - ID PE25 - 250mm  
26389 - ID PE50 - 500mm

**ID**  
**WEBBING SLING**



Part No.: 27845-27869

Part No.:	Size:	Part No.:	Size:	Part No.:	Size:
27845	- 1TON x 3MTR	27854	- 3TON x 6MTR	27863	- 6TON x 4MTR
27846	- 1TON x 6MTR	27855	- 4TON x 3MTR	27864	- 6TON x 5MTR
27847	- 2TON x 3MTR	27856	- 4TON x 6MTR	27865	- 6TON x 6MTR
27848	- 2TON x 4MTR	27857	- 5TON x 3MTR	27866	- 10TON x 3MTR
27849	- 2TON x 5MTR	27858	- 5TON x 4MTR	27867	- 10TON x 4MTR
27850	- 2TON x 6MTR	27859	- 5TON x 5MTR	27868	- 10TON x 5MTR
27851	- 3TON x 3MTR	27860	- 5TON x 6MTR	27869	- 10TON x 6MTR
27852	- 3TON x 4MTR	27861	- 5TON x 8MTR		
27853	- 3TON x 5MTR	27862	- 6TON x 3MTR		

**ID**  
**PALLET TRUCK**



Part No.: 27962

ID PALLET TRUCK

2.5TON.



► **CAULKING GUNS**

**ID ISG295**

**CAULKING GUN**

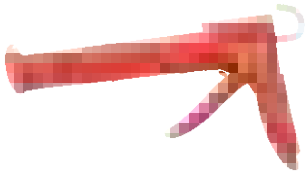

Part No.: 20347

ID ISG295 - 295GMS

CAULKING GUN.

**ID ISG360**

**CAULKING GUN**



Part No.: 23169

ID ISG360 - 360GMS

CAULKING GUN.

**ID ISG405 / 465**

**CAULKING GUN**



Part No.: 23170, 23171

ID ISG405(23170) - 405GSM/  
ID ISG465(23171) - 465GSM

CAULKING GUN.

**ID ISG510A**

**CAULKING GUN**



Part No.: 20348

ID ISG510A - 510GMS

CAULKING GUN.

**ID ISG900D**

**CAULKING GUN**



Part No.: 20349

ID ISG900D - 900GMS

CAULKING GUN.

**ID CGA9**

**CAULKING GUN**



Part No.: 23168

ID CGA9

CAULKING GUN.

**ID CGA15**

**CAULKING GUN**



Part No.: 23167

ID CGA15

CAULKING GUN.



**TORPEDO LEVEL / SPIRIT LEVEL  
COMBINATION SQUARE / HANDLE FILE  
SHARPENING TOOL / METAL TOOL BOX**

*Ideally Advanced, Always!*

**▶▶ TORPEDO LEVEL / SPIRIT LEVEL / COMBINATION SQUARE / HANDLE FILE**

**ID LVE200 / LVE235  
TORPEDO LEVEL**



Part No.: 21553,26739

ID LVE200-21553  
ID LVE235-26739

Torpedo levels with only two tubes are used to determine true horizontal or vertical -- level or plumb.

A level with a third tube set on a 45-degree diagonal is used to check for a 45-degree angle.

**ID LVH...  
SPIRIT LEVEL**

**NEW**



Part No.:	Model No.:	Size:
26740	ID LVH100	4" (100mm)
21545	ID LVH300	12" (300mm)
21548	ID LVH450	18" (450mm)
21549	ID LVH600	24" (600mm)
21550	ID LVH900	36" (900mm)

**ID 65X / 305X  
COMBINATION SQUARE**



Part No.: 26755,20747

ID 65X-26755  
ID 305X-20747

A combination square is a tool used for multiple purposes in woodworking, stonemasonry and metalworking.

**ID HF..  
HANDLE FILE**

(FLAT, HALF ROUND, WOOD ROSP)



Part No.: 20017-26,27997

Model No.:	Type:		
	Flat	Half Round	Wood Rosp
ID HF6	20022	20023	27797
ID HF8	20024	20025	20026
ID HF10	20017	20018	20019
ID HF12	20020	20021	

**▶▶ DIAMOND FILE SETS / SHARPENING TOOL / METAL TOOL BOX**

**ID DF14/16/18/16F  
DIAMOND FILE SETS**



Part No.: 21836-39

ID DF14 - 20836  
ID DF16 - 20838  
ID DF18 - 20839  
ID DF16F - 20837

**ID DS6  
SHARPENING TOOL**



Part No.: 21158

SHARPENING TOOL  
(DIAMOND PATTI)

**ID TB17/21  
METAL TOOL BOX**

**NEW**



Part No.: 20355,20356

ID TB17 - 20355  
ID TB21 - 20356

5 Compartments ( Press To Open ).



**▶▶ HAND RIVETER / DOUBLE PULL RIVETER**

**ID HRD250**

**HAND RIVETER**

**NEW**



Part No.: 25995

Plier Type Hand Riveter

10"(250mm)

**ID HRD260**

**HAND RIVETER**

**NEW**



Part No.: 25994

Plier Type Hand Riveter

10"(250mm)

**ID HRD17**

**DOUBLE PULL RIVETER**

**NEW**



Part No.: 25996

Bold Cutter Type Hand Riveter

17"(430mm)

**ID HRD21**

**DOUBLE PULL RIVETER**

**NEW**



Part No.: 25997

Bold Cutter Type Hand Riveter

21"(533mm)

**▶▶ HAND RIVETER / PNEUMATIC RIVETING GUN / ELECTRIC RIVETER / PVC PIPE CUTTER**

**IDHR32**

**HAND RIVETER**

**NEW**



Part No.: 26068

Lazy Tong Hand Riveter

32"(812mm)

**ID AR53**

**PNEUMATIC RIVETING GUN**

**NEW**



Part No.: 26072

Pneumatic Riveting Gun.

**ID ERC52**

**ELECTRIC RIVETER**

**NEW**



Part No.: 25992

Rivet Attachment For Drill Machine.

**ID PC42**

**PVC PIPE CUTTER**

**NEW**



Part No.: 26071

PVC Pipe Cutter.

**▶▶ GREASE GUN**

**ID GG450**

**GREASE GUN**

**NEW**



Part No.: 26070

Grease Gun

18"(450mm).



*Ideally Advanced, Always!*



# ASIA'S MOST POPULAR BRAND

DEALER



**IDEAL INTERNATIONAL POWER TOOLS PVT. LTD.**

[www.idealpowertools.org](http://www.idealpowertools.org)